

New Zealand Gazette

WELLINGTON: THURSDAY, 27 AUGUST 1998

CONTENTS

COMMERCIAL

Bankruptcy Notices	2988
Company Notices—	
Appointment and Release of Receivers	2991
Applications for Winding Up/Liquidations	2991
Voluntary Winding Up and First Meetings	None
Appointment and Release of Liquidators	2999
Meetings and Last Dates by Which to Prove Debts or Claims	3003
Removals	3005
Cessation of Business in New Zealand	3018
Alteration of Memorandum of Association	None
Partnership Notices	None
Other	3019
Land Transfer Notices	3020
Charitable Trusts Notices	3023

Friendly Societies and Credit Unions Notices	3023
Incorporated Societies Notices	None
General Notices	None

GOVERNMENT

Vice Regal	None
Parliamentary Notices	None
Private Bills	None
Departmental Notices	3023
Authorities and Other Agencies of State Notices	3038
Land Notices	3040
Regulation Summary	3051
General Section	3052
Deadlines	None
Index	3059

USING THE GAZETTE

The *New Zealand Gazette*, the official newspaper of the Government of New Zealand, is published weekly on Thursday. Publishing time is 4 p.m.

Closing time for lodgment of notices under the Companies, Partnership, Insolvency and Land Transfer Acts is 12 noon on Monday (except where that day is a public holiday, in which case the deadline will be noon on the last working day of the preceding week). **All other notices must be lodged at the Gazette Office by 12 noon, Tuesday in the week of publication.**

Notices are accepted for publication in the next available issue, unless otherwise specified.

Notices being submitted for publication must be reproduced copies of the originals. Dates, proper names and

signatures are to be shown clearly. A covering instruction setting out requirements must accompany all notices.

Copy will be returned unpublished if not submitted in accordance with these requirements.

Notices for publication and related correspondence should be addressed to:

Gazette Office,
Department of Internal Affairs,
P.O. Box 805,
Wellington.
Telephone: (04) 470 2930 / (04) 470 2931.
Facsimile: (04) 470 2932.
Email: gazette@parliament.govt.nz

Cancelled Notices

Notices cancelled after being accepted for publication will be subject to a charge of \$55 to cover setting up and deleting costs. The deadline for cancelling notices is 3 p.m. on Wednesdays.

Availability

The *New Zealand Gazette* is available on subscription from G.P. Legislation Services, P.O. Box 12-418, Wellington (Telephone: (04) 496 5694), or over the counter at the following locations:

Bennetts Bookshop Limited

Level One, Whitcoulls Corner Store, Queen Street, **Auckland.**

Whitcoulls, 111 Cashel Street, **Christchurch.**

Whitcoulls Shop Bookshop, 143 George Street, **Dunedin.**

38-42 Broadway Avenue, **Palmerston North.**

Massey University, **Palmerston North.**

Whitcoulls, Centreplace, Bryce Street, **Hamilton.**

Bowen House, Lambton Quay, **Wellington.**

Other issues of the Gazette

Customs Edition—Published weekly on Tuesdays.

Special Editions, Professional & Trade lists and Supplements—Published as and when required.

Advertising Rates

The following rates for the insertion of materials in the *New Zealand Gazette* apply as from 1 January 1998:

Category 1

Single column notices, e.g.: Notices under the Companies Act, Insolvency Act, and Public Works Act—55c per word (no matter how big or small)*.

Category 2

Notices in table form or taking up two columns across the page, e.g.: Change of Company Name notices, Regulation Summaries—60c per word (no matter how big or small)*.

*Any word or group of alphas or numerals with a comma or full point imbedded in it will count as two words.

*Any word or letter ending with a full point, comma, shilling stroke (whether followed by a word space or no word space will count as one word, e.g., D.X. = 2 words, the end. = 2 words. The full point, comma, shilling stroke ends the word, and what follows starts another word.)

The appropriate rate to be applied to an advertisement will be determined at the time of setting up the notice for publication. Customers will be invoiced in accordance with standard commercial practices. Advertising rates are not negotiable.

All rates shown are inclusive of G.S.T.

Bankruptcy Notices

Bankruptcy Notices**Auckland**

The following people were adjudicated bankrupt on the dates below:

31 July 1998

Shepherd, Roger Bayley, gardener of 104 Hatea Drive, Whangarei (trading as Roger B. Shepherd).

3 August 1998

Innes, Alan Russell, computer network analyst of 41/258 Parnell Road, Parnell.

4 August 1998

Hurdell, Sean John, purchasing officer and **Hurdell, Vanita Carmen**, both of 1/70 Marne Road, Papakura (trading as Hurdell Coffee Lounge).

Hodge, Gina Suzanne of 146 Queen Street, Pukekohe.

Low, Nathan James, shop assistant and **Low, Elizabeth Jane**, both of 44 Fairclough Road, Beachhaven.

Thorburn, Stacy Jay, restaurateur of Owhiwa Road, R.D. 1, Onerahi.

5 August 1998

Bezley, James Clendon, self employed of 73 Kervil Avenue, Te Atatu South.

Kirkbride, Gary, labourer of 31 Deverell Place, Browns Bay (trading as Phoenix Foundation).

Livingstone, Gary James, self employed of 20A Jonathan Place, Forrest Hill.

Rota, Tui John, self employed of 3I Harrybrook Road, Green Bay.

Sylva, Marie Louise, cartage contractor of 25 Clarkes Beach Road, Clarkes Beach.

6 August 1998

Menzies, Teresa Claudine, home executive of 73 Rautawhiri Road, Helensville.

Sproule, Vickie Lee, beneficiary of 3 Boakes Road, Mount Wellington.

7 August 1998

Ingram, Jason McDuff, cabinetmaker of 37 Sorrel Crescent, Bucklands Beach (trading as B. J. Kitchens & Furniture).

Leverque, Melinda Julie, part-time bookkeeper of 12 Santa Monica Place, Manukau City.

10 August 1998

Pritchard, Graham Arthur, student of 57A Verran Road, Birkenhead (trading as J. P. Builders).

Toopi, Barbara Elizabeth, beneficiary of Unit 2, Longreach Drive, Glendene.

11 August 1998

Purdy, Deborah Joanne of 33 Punga Road, Whenuapai.

Watson, Mathew John, self employed of 25 Peel Street, Grey Lynn (trading as Euroscooter).

Shinnick, Desmond Anthony, company director of Strathnaver Crescent, Lynfield.

12 August 1998

Collins, John Gerard, worker, care of The Immigrant Irish Bar, 1/104 Fanshawe Street, Auckland.

Edwards, Roy William, address unknown.

Hawkes, Michael, self employed of 14 Glamorgan Drive, Torbay.

Mundy, Neil Thomas, landscape contractor of 2/62 Glenandrew Drive, Half Moon Bay.

Roil, Wayne Gregory of 170 Hepburn Road, Glendene.

Tittleton, Wayne, landscaper of 6 Monowai Street, Wellsford.

13 August 1998

Harrison, Shane of 70 Albert Street, Kawakawa.

Herk, Tony Reginald, builder of Pomare Road, Russell.

Jensen, Roy Alan of 27 Beasley Crescent, Whangarei.

Toki, Hamana Francis, painter and paperhanger of 3 Belmont Place, Kaikohe.

Reid, Tunui Lesley Gaye and **Reid, David William**, both painters and decorators of 3 Balmoral Drive, Tikipunga, Whangarei.

14 August 1998

Bonanza, Reynoldo of 2/51 Cromdale Avenue, Howick.

Canty, Peter Michael, care of the Nurses Home, Kaitaia Hospital, Kaitaia.

Rawnsley-Smith, Antony Paul, building contractor of 63 Annandale Road, Howick.

Russell, Cary Frederick of 20 Manuka Road, Blackpool, Waiheke Island.

17 August 1998

Freeson, Richard James, window cleaner of 10A Sumich Place, West Harbour.

18 August 1998

Nelson, Cary Donald, builder of 41 Asquith Avenue, Mount Albert (trading as Nelson Developments and C. D. Nelson).

BUSINESS AND REGISTRIES BRANCH.

Ministry of Commerce, Private Bag 92-513, Wellesley Street, Auckland. Telephone: (09) 357 4141. Facsimile: (09) 357 1776.

ba5988

In Bankruptcy

Christchurch

The following persons were adjudicated bankrupt on the dates below:

10 August 1998

Barrow, Wayne James, beneficiary of Two Chain Road, R.D. 5, Christchurch.

Drummond, Kiri Jane (also known as **Brown, Ross**), beneficiary of 31 Pateke Place, Christchurch.

Tangimetua, Noel, occupation unknown of 125 Birchwood Road, Ohai, Southland.

11 August 1998

Bonny, Maria Anne, beneficiary of 16 Karna Street, Maitaia (previously trading as Southern Haulage).

Hancock-Manning, Tania Carolyn, occupation unknown of 36B Thomas Street, Temuka.

Kerr, Loretta May, beneficiary, care of 6 Browne Street, Timaru.

Ling, Lynette Alison, house manager of 66 Cutts Road, Christchurch (previously trading as Calypso Tent).

12 August 1998

Chapman, Lynette Marea, home executive and **Chapman, Michael Kieran**, driver of 9 Russell Street, Winton.

Minards, Christine Ruth and **Rees, Barry Peter**, beneficiaries of 169A Bridge Street, Nelson (previously trading in partnership as Landmark Cafe & Wine Bar).

13 August 1998

Cassells, Brenda Marie, manager of 58 Achilles Street, Christchurch.

Drummond, Andrew Eian, beneficiary of 31 Pateke Place, Christchurch.

Neale, Lynette, cleaner of 292 Waterloo Road, Christchurch.

Williams, David Gareth, beneficiary of 74 Mathesons Road, Christchurch.

14 August 1998

Valentine, Dennis William, company director of Christchurch.

West, James Colin, labourer of 1/134 Salisbury Street, Christchurch.

17 August 1998

McDonald, Eric John, beneficiary of 111 Richard Pearse Drive, Temuka.

18 August 1998

Ching, Lance Bradley, chef of 12 Lagan Street, Christchurch (previously trading as Arizona's Cafe Bar).

Moore, Arthur Francis, retired of No. 1 R.D., Waikouaiti.

Priestley, Jill, hospital assistant of 4/27 Whitmore Street, Christchurch.

Workman, Peter Anthony, beneficiary of 274 Williams Street, Kaiapoi.

19 August 1998

Burrows, Ian Andrew, seasonal worker of 8 Bank Street, Blenheim.

Hunter, Sam Bill, labourer of 8 Miller Street, Invercargill.

Porter, Glenda Mae, solo parent of 26 Oakland Street, Christchurch.

20 August 1998

Allington, Douglas John, contractor of 18 Moncks Spur Road, Christchurch.

Bowers, Kevin Wayne, furniture manufacturer of Heyders Road, Spencerville (previously trading as Regal Furniture).

Gay, Lorraine Angela, mother of 31 Lorn Street, Invercargill.

Jager, Mark, beneficiary of 187 Alford Forest Road, R.D., Ashburton.

Strang, Mary Moana, beneficiary of 73A Burns Street, Dunedin.

21 August 1998

Chambers, Gareth John Sutton, beneficiary of 31 Williams Street, Timaru.

Scott, Stuart David, casual worker of 164A Waimairi Road, Christchurch.

OFFICIAL ASSIGNEE.

New Zealand Insolvency and Trustee Service, Private Bag 4714, Christchurch. Telephone: (03) 371 7070. Facsimile: (03) 371 7071.

ba6131

In Bankruptcy**Hamilton**

The following persons were adjudicated bankrupt on the dates below:

27 May 1998

Riddick, Gavin Bruce and **Riddick, Diane Fay**, sharemilkers, formerly of Salisbury Road, R.D. 24, Stratford, now of 272 Upland Road, R.D. 2, New Plymouth.

11 August 1998

Haman, Glyndwr William, student, formerly of 171 Sandwich Road, Hamilton and 35 Cullimore Street, Hamilton, now of 50 Heath Street, Hamilton (previously trading as G W Haman, Hypnotherapist).

Riddell, Keith Warren, engineer, formerly of 35C Scantlebury Street, Tauranga and 321 Fraser Street, Tauranga, now of 8/61 Maleme Street, Tauranga.

Mayor, Dawn, retail assistant, formerly of 10 Park Place, Taupo and Taharepa Road, Taupo, now of 51B Marshall Avenue, Taupo.

12 August 1998

Nott, Allan Desmond, builder of 300 R.D. 2, Omokoroa (previously trading as A D Nott Property Development).

Dickie, Philip Arthur, manager of 176 Russell Road, Manurewa, Auckland.

Asafo, Iuriana Chloe, telephone operator of 14 McBurney Place, Mangere East, Auckland.

Jones, Murray Ross of 187 Symonds Street, Newton, Auckland.

Balajaran, S. of 15 Casuarina Road, Bucklands Beach, Auckland.

Martin, Allen John of B5/1 Bereford Street, Auckland.

Gu, Qing Ping, butcher of 763 Remuera Road, Auckland.

13 August 1998

Brand, Toni Robyn, unemployed, formerly of 7C Dommet Street, New Plymouth, now of 19 Marama Crescent, New Plymouth.

Portland, Brian James, broadcaster, formerly of 22 Thames Street, Hamilton, 24 Gibson Street, Hamilton, 70 Raurimu Avenue, Whangarei and 296 Kamo Road, Whangarei.

O'Sullivan, Julie Kim, clerk of 26C Annandale Street, New Plymouth (previously trading as Egmont Directional Drilling).

Houghton, Pauline Margaret, unemployed, formerly of 17 Konini Street, Inglewood and 4A Puriri Street, Inglewood, now care of Bristol Road, R.D. 8, Inglewood.

17 August 1998

Ngati, Ben Leslie, formerly of 25A Lyn Grove, Papamoa, now of 1144 Papamoa Beach Road, Papamoa.

Thrupp, Fred, work person of 10/10 Eason Street, Greenholme, Rotorua.

Arnold, Bruno, farmer of Oldina Road, Wynyard 7325, Tasmania, Australia.

Johnson, Keryn Maree, sickness beneficiary, formerly of 27 Watson Street, New Plymouth, now care of 6 Durham Avenue, New Plymouth.

Stannard, James Lawrence, polisher, formerly of

74 Cordelia Street, Stratford, now of 912 Bird Road, R.D. 23, Stratford.

18 August 1998

Hapi, Sharyn Te-Auta, invalids beneficiary of 11A Blake Street, Hamilton.

George, Faye Teresa, mother, formerly of Oliva Street, Stratford, Jamieson Crescent, Hamilton and 143 Celia Street, Stratford, now of 8 Avon Street, Stratford.

19 August 1998

Johnston, Shannon Damien Phinlo, polytech student, formerly of 140 Vivian Street, New Plymouth and 10A Mahoe Street, New Plymouth, now of 10 Totara Terrace, Inglewood.

Grundy, David Craig of 84 Holly Street, Avondale, Auckland.

Lardner, Shane, self employed of 178 Whitney Street, Blockhouse Bay, Auckland.

Hutton, Anthony Maurice, financial advisor of 28 Esmeralda Avenue, Avondale, Auckland.

Hackshaw, Andrew Thomas and **Hackshaw, Suzanne Joy**, both of 9 Truscott Place, Massey, Auckland.

20 August 1998

Holcroft, Mike, electrician of 47C Winstone Avenue, Hamilton (previously trading as Just Add Water).

Andrews, Paul Brent, unemployed, formerly of 27 Chester Street, Tauranga, 211A Darraghs Road, Tauranga and 113 Grange Road, Tauranga, now of 41A Meander Drive, Tauranga.

Martin, Paul James, sickness beneficiary of 2 George Street, Matamata.

21 August 1998

Gray, Darwin Hamiora, unemployed, formerly of 63 St Andrews Drive and 73 St Andrews Drive, Tokoroa, now of 8 Fife Place, Tokoroa.

Lepa, Veronica Malia, unemployed, formerly of 63 St Andrews Drive, 73 St Andrews Drive and 94 Grampian Street, Tokoroa, now of 8 Fife Place, Tokoroa.

Strongman, Donne Jeremy, beneficiary, formerly of 474A Beach Road, Papamoa, Mount Maunganui and 621 Welcome Bay Road, Welcome Bay, Tauranga, now care of 41 Kingswood Road, Tauranga.

OFFICIAL ASSIGNEE.

New Zealand Insolvency and Trustee Service, Private Bag 3090, Hamilton. Telephone: (07) 839 5055. Facsimile: (07) 839 0388.

ba6128

Notice of Order Annuling an Adjudication**Pursuant to Section 119 (1) (b) of the Insolvency Act 1967**

Take notice that the order of adjudication dated the 17th day of May 1995 against **Brett Drake** of Auckland, was annulled by order of the High Court of Auckland dated the 22nd day of April 1998.

Dated at Auckland this 3rd day of August 1998.

D. M. MARSHALL, Deputy Official Assignee.

ba5986

Company Notices

APPOINTMENT AND RELEASE OF RECEIVERS

Waihemo Timber Company (1997) Limited (in receivership)

Notice of Appointment of Receivers

Pursuant to Section 8 (1) (b) of the Receiverships Act 1993

On the 14th day of August 1998, we, Stephen John Tubbs and Guy Patrick Pierce, were appointed to act jointly and severally as receivers of all the property of the above-named company.

Our Office Address is: Pierce/Tubbs, Chartered Accountants, Level Three, 167 Victoria Street, Christchurch.

Our Postal Address is: Pierce/Tubbs, P.O. Box 2283, Christchurch.

STEPHEN J. TUBBS and GUY P. PIERCE.

ar5981

Coastal Aluminium (1996) Limited

Notice of Appointment of Receivers and Managers

Pursuant to Section 8 (1) (b) of the Receiverships Act 1993

We, Michael Peter Stiassny and Grant Robert Graham, hereby give notice that on the 20th day of August 1998, we were appointed joint and several receivers and managers of the assets and undertakings of Coastal Aluminium (1996) Limited, pursuant to a debenture dated the 7th day of November 1996.

Short Description of Property Charged Under the Debenture: All assets and undertakings of the company.

The Office of the Receivers and Managers is at: Ferrier Hodgson & Co, Sixteenth Floor, Southpac Tower, 45 Queen Street, Auckland.

Inquiries to: Guy Baxendale.

ar6053

Fast Forward Moulding Limited (in receivership) and Fast Forward Blowmoulding Limited (in receivership) ("the companies")

Notice of Appointment of Receivers and Notice of Cessation of Receiverships

Richard Dale Agnew and Colin Thomas McCloy, chartered accountants of Auckland, were appointed receivers and managers of the companies on the 7th day of August 1998, under the terms of debentures, giving fixed and floating charges over the whole of the assets of the companies.

The Property in Receivership is: All of the companies' undertaking, property and assets.

The receiverships ceased on the 21st day of August 1998.

The Receivers' Address is: PricewaterhouseCoopers, Coopers & Lybrand Tower, Level Twenty-nine, 23-29 Albert Street (Private Bag 92-162), Auckland.

Dated this 21st day of August 1998.

ar6125

APPLICATIONS FOR WINDING UP / LIQUIDATIONS

Advertisement of Application for Putting Company into Liquidation

M. No. 1225/98

Take notice that on the 22nd day of July 1998, an application for putting **OC & RS Williams Limited** into liquidation by the High Court was filed in the High Court at Auckland.

The application is to be heard before the High Court at Auckland on Thursday, the 10th day of September 1998 at 10.45 a.m.

Any person, other than the defendant company, who wishes to appear on the hearing of the application must file an appearance not later than the second working day before that day.

The applicant is **The Commissioner of Inland Revenue**, whose address for service is Simon John Eisdell Moore, Crown Solicitor, care of Meredith Connell & Co., Sixth Floor, General Building, 29 Shortland Street (P.O. Box 2213 or D.X. C.P. 24-063), Auckland (*Inquiries to:* L. Read).

Further particulars may be obtained from the office of the Court or from the applicant or the applicant's solicitor.

S. J. EISDELL MOORE, Solicitor for the Applicant.

aw6060

Advertisement of Application for Putting Company into Liquidation

M. No. 1224/98

Take notice that on the 22nd day of July 1998, an application for putting **Ruapehu Directional Drilling Limited** (in receivership) into liquidation by the High Court was filed in the High Court at Auckland.

The application is to be heard before the High Court at Auckland on Thursday, the 10th day of September 1998 at 10.45 a.m.

Any person, other than the defendant company, who wishes to appear on the hearing of the application must file an appearance not later than the second working day before that day.

The applicant is **The Commissioner of Inland Revenue**, whose address for service is Simon John Eisdell Moore, Crown Solicitor, care of Meredith Connell & Co., Sixth Floor, General Building, 29 Shortland Street (P.O. Box 2213 or D.X. C.P. 24-063), Auckland (*Inquiries to:* L. Read).

Further particulars may be obtained from the office of the Court or from the applicant or the applicant's solicitor.

S. J. EISDELL MOORE, Solicitor for the Applicant.

aw6061

Advertisement of Application for Putting Company into Liquidation

M. No. 1391/98

Take notice that on the 6th day of August 1998, an application for putting **Alwest Aluminium Limited** into liquidation by the High Court was filed in the High Court at Auckland.

The application is to be heard before the High Court at Auckland on Thursday, the 10th day of September 1998 at 10.45 a.m.

Any person, other than the defendant company, who wishes to appear on the hearing of the application must file an appearance not later than the second working day before that day.

The applicant is **The Commissioner of Inland Revenue**, whose address for service is Simon John Eisdell Moore, Crown Solicitor, care of Meredith Connell & Co., Sixth Floor, General Building, 29 Shortland Street (P.O. Box 2213 or D.X. C.P. 24-063), Auckland (*Inquiries to:* R. E. Harvey).

Further particulars may be obtained from the office of the Court or from the applicant or the applicant's solicitor.

S. J. EISDELL MOORE, Solicitor for the Applicant.

aw6105

Advertisement of Application for Putting Company into Liquidation

M. No. 1392/98

Take notice that on the 6th day of August 1998, an application for putting **Cosfort Holdings Limited** into liquidation by the High Court was filed in the High Court at Auckland.

The application is to be heard before the High Court at Auckland on Thursday, the 10th day of September 1998 at 10.00 a.m.

Any person, other than the defendant company, who wishes to appear on the hearing of the application must file an appearance not later than the second working day before that day.

The applicant is **The Commissioner of Inland Revenue**, whose address for service is Simon John Eisdell Moore, Crown Solicitor, care of Meredith Connell & Co., Sixth Floor, General Building, 29 Shortland Street (P.O. Box 2213 or D.X. C.P. 24-063), Auckland (*Inquiries to:* R. E. Harvey).

Further particulars may be obtained from the office of the Court or from the applicant or the applicant's solicitor.

S. J. EISDELL MOORE, Solicitor for the Applicant.

aw6107

Advertisement of Application for Putting Company into Liquidation

M. No. 1420/98

Take notice that on the 11th day of August 1998, an application for putting **Hallam Engineering Limited** into liquidation by the High Court was filed in the High Court at Auckland.

The application is to be heard before the High Court at Auckland on Thursday, the 10th day of September 1998 at 10.45 a.m.

Any person, other than the defendant company, who wishes to appear on the hearing of the application must file an

appearance not later than the second working day before that day.

The applicant is **The Commissioner of Inland Revenue**, whose address for service is Simon John Eisdell Moore, Crown Solicitor, care of Meredith Connell & Co., Sixth Floor, General Building, 29 Shortland Street (P.O. Box 2213 or D.X. C.P. 24-063), Auckland (*Inquiries to:* R. E. Harvey).

Further particulars may be obtained from the office of the Court or from the applicant or the applicant's solicitor.

S. J. EISDELL MOORE, Solicitor for the Applicant.

aw6108

Advertisement of Application for Putting Company into Liquidation

M. No. 1401/98

Take notice that on the 7th day of August 1998, an application for putting **Magneto Properties Limited** into liquidation by the High Court was filed in the High Court at Auckland.

The application is to be heard before the High Court at Auckland on Thursday, the 10th day of September 1998 at 10.45 a.m.

Any person, other than the defendant company, who wishes to appear on the hearing of the application must file an appearance not later than the second working day before that day.

The applicant is **The Commissioner of Inland Revenue**, whose address for service is Simon John Eisdell Moore, Crown Solicitor, care of Meredith Connell & Co., Sixth Floor, General Building, 29 Shortland Street (P.O. Box 2213 or D.X. C.P. 24-063), Auckland (*Inquiries to:* R. E. Harvey).

Further particulars may be obtained from the office of the Court or from the applicant or the applicant's solicitor.

S. J. EISDELL MOORE, Solicitor for the Applicant.

aw6109

Advertisement of Application for Putting Company into Liquidation

M. No. 1395/98

Take notice that on the 7th day of August 1998, an application for putting **Plumley Holdings Limited** (in receivership) into liquidation by the High Court was filed in the High Court at Auckland.

The application is to be heard before the High Court at Auckland on Thursday, the 10th day of September 1998 at 10.45 a.m.

Any person, other than the defendant company, who wishes to appear on the hearing of the application must file an appearance not later than the second working day before that day.

The applicant is **The Commissioner of Inland Revenue**, whose address for service is Simon John Eisdell Moore, Crown Solicitor, care of Meredith Connell & Co., Sixth Floor, General Building, 29 Shortland Street (P.O. Box 2213 or D.X. C.P. 24-063), Auckland (*Inquiries to:* R. E. Harvey).

Further particulars may be obtained from the office of the Court or from the applicant or the applicant's solicitor.

S. J. EISDELL MOORE, Solicitor for the Applicant.

aw6110

Advertisement of Application for Putting Company into Liquidation

M. No. 321/98

Take notice that on the 12th day of August 1998, an application for putting **Sash Painting Services Limited** into liquidation by the High Court was filed in the High Court at Wellington.

The application is to be heard before the High Court at Wellington on the 7th day of September 1998 at 10.00 a.m.

Any person, other than the defendant company, who wishes to appear on the hearing of the application must file an appearance not later than the second working day before that day.

The applicant is **The Commissioner of Inland Revenue**, whose address for service is at the offices of Messrs Luke, Cunningham & Clere, Solicitors, Level Nine, 105 The Terrace, Wellington.

Further particulars may be obtained from the office of the Court or from the applicant or the applicant's solicitor.

K. G. STONE, Solicitor for the Applicant.

aw6026

Advertisement of Application for Putting Company into Liquidation

M. No. 323/98

Take notice that on the 13th day of August 1998, an application for putting **Wellington Concrete Products Limited** into liquidation by the High Court was filed in the High Court at Wellington.

The application is to be heard before the High Court at Wellington on the 7th day of September 1998 at 10.00 a.m.

Any person, other than the defendant company, who wishes to appear on the hearing of the application must file an appearance not later than the second working day before that day.

The applicant is **The Commissioner of Inland Revenue**, whose address for service is at the offices of Messrs Luke, Cunningham & Clere, Solicitors, Level Nine, 105 The Terrace, Wellington.

Further particulars may be obtained from the office of the Court or from the applicant or the applicant's solicitor.

K. G. STONE, Solicitor for the Applicant.

aw6027

Advertisement of Application for Putting Company into Liquidation

M. No. 329/98

Take notice that on the 14th day of August 1998, an application for putting **Meichtry Investments Limited** into liquidation by the High Court was filed in the High Court at Wellington.

The application is to be heard before the High Court at Wellington on the 7th day of September 1998 at 10.00 a.m.

Any person, other than the defendant company, who wishes to appear on the hearing of the application must file an appearance not later than the second working day before that day.

The applicant is **The Commissioner of Inland Revenue**, whose address for service is at the offices of Messrs Luke, Cunningham & Clere, Solicitors, Level Nine, 105 The Terrace, Wellington.

Further particulars may be obtained from the office of the Court or from the applicant or the applicant's solicitor.

K. G. STONE, Solicitor for the Applicant.

aw6028

Advertisement of Application for Putting Company into Liquidation

M. No. 324/98

Take notice that on the 13th day of August 1998, an application for putting **Metro Consulting Limited** into liquidation by the High Court was filed in the High Court at Wellington.

The application is to be heard before the High Court at Wellington on the 7th day of September 1998 at 10.00 a.m.

Any person, other than the defendant company, who wishes to appear on the hearing of the application must file an appearance not later than the second working day before that day.

The applicant is **The Commissioner of Inland Revenue**, whose address for service is at the offices of Messrs Luke, Cunningham & Clere, Solicitors, Level Nine, 105 The Terrace, Wellington.

Further particulars may be obtained from the office of the Court or from the applicant or the applicant's solicitor.

K. G. STONE, Solicitor for the Applicant.

aw6029

Advertisement of Application for Putting Company into Liquidation

M. No. 317/98

Take notice that on the 7th day of August 1998, an application for putting **Bangkok Kitchen and Bar Limited** into liquidation by the High Court was filed in the High Court at Wellington.

The application is to be heard before the High Court at Wellington on the 7th day of September 1998 at 10.00 a.m.

Any person, other than the defendant company, who wishes to appear on the hearing of the application must file an appearance not later than the second working day before that day.

The applicant is **The Commissioner of Inland Revenue**, whose address for service is at the offices of Messrs Luke, Cunningham & Clere, Solicitors, Level Nine, 105 The Terrace, Wellington.

Further particulars may be obtained from the office of the Court or from the applicant or the applicant's solicitor.

K. G. STONE, Solicitor for the Applicant.

aw5968

Advertisement of Application for Putting Company into Liquidation

M. No. 234/98

Take notice that on the 12th day of June 1998, an application for putting **G. W. Rennwandt Limited** into liquidation by the High Court was filed in the High Court at Wellington.

The application is to be heard before the High Court at Wellington on the 7th day of September 1998 at 10.00 a.m.

Any person, other than the defendant company, who wishes to appear on the hearing of the application must file an appearance not later than the second working day before that day.

The applicant is **The Commissioner of Inland Revenue**,

whose address for service is at the offices of Messrs Luke, Cunningham & Clere, Solicitors, Level Nine, 105 The Terrace, Wellington.

Further particulars may be obtained from the office of the Court or from the applicant or the applicant's solicitor.

K. G. STONE, Solicitor for the Applicant.

aw6141

Advertisement of Application for Putting Company into Liquidation

M. No. 453/98

Take notice that on the 11th day of August 1998, an application for putting **Top Notch Plasterers Limited** into liquidation by the High Court was filed in the High Court at Christchurch.

The application is to be heard before the High Court at Christchurch on Monday, the 7th day of September 1998 at 9.30 a.m.

Any person, other than the defendant company, who wishes to appear on the hearing of the application must file an appearance not later than the second working day before that day.

The applicant is **The Commissioner of Inland Revenue**, whose address for service is Technical and Legal Support Group, Christchurch Service Centre, First Floor, 165 Cashel Street (P.O. Box 1782), Christchurch. Telephone: (03) 363 1875. Facsimile: (03) 363 1519.

Further particulars may be obtained from the office of the Court or from the applicant or the applicant's solicitor.

HELEN ROSE SUMNER (MRS), Solicitor for the Applicant.

aw6121

Advertisement of Application for Putting Company into Liquidation

M. No. 451/98

Take notice that on the 11th day of August 1998, an application for putting **New Zealand Dairy System Limited** into liquidation by the High Court was filed in the High Court at Christchurch.

The application is to be heard before the High Court at Christchurch on Monday, the 7th day of September 1998 at 9.30 a.m.

Any person, other than the defendant company, who wishes to appear on the hearing of the application must file an appearance not later than the second working day before that day.

The applicant is **The Commissioner of Inland Revenue**, whose address for service is Technical and Legal Support Group, Christchurch Service Centre, First Floor, 165 Cashel Street (P.O. Box 1782), Christchurch. Telephone: (03) 363 1875. Facsimile: (03) 363 1519.

Further particulars may be obtained from the office of the Court or from the applicant or the applicant's solicitor.

HELEN ROSE SUMNER (MRS), Solicitor for the Applicant.

aw6122

Advertisement of Application for Putting Company into Liquidation

M. No. 441/98

Take notice that on the 6th day of August 1998, an application for putting **Saxony System Limited** into

liquidation by the High Court was filed in the High Court at Christchurch.

The application is to be heard before the High Court at Christchurch on Monday, the 7th day of September 1998 at 9.30 a.m.

Any person, other than the defendant company, who wishes to appear on the hearing of the application must file an appearance not later than the second working day before that day.

The applicant is **The Commissioner of Inland Revenue**, whose address for service is Technical and Legal Support Group, Christchurch Service Centre, First Floor, 165 Cashel Street (P.O. Box 1782), Christchurch. Telephone: (03) 363 1875. Facsimile: (03) 363 1519.

Further particulars may be obtained from the office of the Court or from the applicant or the applicant's solicitor.

HELEN ROSE SUMNER (MRS), Solicitor for the Applicant.

aw6123

Advertisement of Application for Putting Company into Liquidation

M. No. 440/98

Take notice that on the 6th day of August 1998, an application for putting **Rushden Properties Limited** into liquidation by the High Court was filed in the High Court at Christchurch.

The application is to be heard before the High Court at Christchurch on Monday, the 7th day of September 1998 at 9.30 a.m.

Any person, other than the defendant company, who wishes to appear on the hearing of the application must file an appearance not later than the second working day before that day.

The applicant is **The Commissioner of Inland Revenue**, whose address for service is Technical and Legal Support Group, Christchurch Service Centre, First Floor, 165 Cashel Street (P.O. Box 1782), Christchurch. Telephone: (03) 363 1875. Facsimile: (03) 363 1519.

Further particulars may be obtained from the office of the Court or from the applicant or the applicant's solicitor.

HELEN ROSE SUMNER (MRS), Solicitor for the Applicant.

aw6124

Advertisement of Application for Putting Company into Liquidation

M. No. 43/98

Take notice that on the 4th day of August 1998, an application for putting **Te Aupouri Ngatikahu Te Rarawa Trust** into liquidation by the High Court was filed in the High Court at Whangarei.

The application is to be heard before the High Court at Whangarei on Monday, the 14th day of September 1998 at 10.00 a.m.

Any person, other than the defendant company, who wishes to appear on the hearing of the application must file an appearance not later than the second working day before that day.

The applicant is **The Commissioner of Inland Revenue**, whose address for service is at the office of P. J. Smith, Crown Solicitor, Marsden Woods, Inskip & Smith, Solicitors, 122 Bank Street (P.O. Box 146), Whangarei.

Further particulars may be obtained from the office of the Court or from the applicant or the applicant's solicitor.

M. B. SMITH, Counsel for the Applicant.

aw6111

Advertisement of Application for Putting Company into Liquidation

M. No. 39/98

Take notice that on the 21st day of July 1998, an application for putting **Friends Restaraunt Limited** into liquidation by the High Court was filed in the High Court at Whangarei.

The application is to be heard before the High Court at Whangarei on Monday, the 14th day of September 1998 at 10.00 a.m.

Any person, other than the defendant company, who wishes to appear on the hearing of the application must file an appearance not later than the second working day before that day.

The applicant is **The Commissioner of Inland Revenue**, whose address for service is at the office of P. J. Smith, Crown Solicitor, Marsden Woods, Inskip & Smith, Solicitors, 122 Bank Street (P.O. Box 146), Whangarei.

Further particulars may be obtained from the office of the Court or from the applicant or the applicant's solicitor.

M. B. SMITH, Counsel for the Applicant.

aw6113

Advertisement of Application for Putting Company into Liquidation by the Court

M. No. 39/98

Take notice that on the 7th day of July 1998, an application for putting into liquidation **Turbo Designer Menswear Limited** by the High Court was filed in the High Court at Tauranga.

The application is to be heard before the High Court at Rotorua on Monday, the 21st day of September 1998 at 11.45 a.m.

Any person, other than the defendant company, who wishes to appear on the hearing of the application must file an appearance not later than the second working day before that day.

The applicant is **The Commissioner of Inland Revenue**, whose address for service is at the offices of the Inland Revenue Department, Claudelands Road, Hamilton.

Further particulars may be obtained from the office of the Court or from the applicant or the applicant's solicitor.

M. J. HARDIE, Solicitor for the Applicant.

aw6139

Advertisement of Application for Putting Company into Liquidation

M. No. 1368/98

Take notice that on the 5th day of August 1998, an application for putting **Global Mortgage Securities Limited** into liquidation by the High Court was filed in the High Court at Auckland.

The application is to be heard before the High Court at Auckland on the 3rd day of September 1998 at 10.45 a.m.

Any person, other than the defendant company, who wishes to appear on the hearing of the application must file an appearance not later than the second working day before that date.

The applicant is **W Stevenson and Sons Limited**, whose address for service is at the offices of Messrs Craig Griffin & Lord, Solicitors, 187 Mount Eden Road, Mount Eden (P.O. Box 9049, Newmarket), Auckland.

Further particulars may be obtained from the office of the Court or from the applicant or the applicant's solicitor.

C. N. LORD, Solicitor for the Applicant.

aw6062

Advertisement of Application for Putting Company into Liquidation

M. No. 1365/98

Take notice that on the 31st day of July 1998, an application to put **West Penn Holdings Limited** into liquidation was filed in the High Court at Auckland.

The application is to be heard before the High Court at Auckland on the 3rd day of September 1998 at 10.45 a.m.

Any person, other than the defendant company, who wishes to appear on the hearing of the application must file an appearance not later than the second working day before that day.

The applicant is **Quando Corporation Limited**, whose address for service is Carter & Partners, Level Eleven, 99 Queen Street, Auckland.

Further particulars may be obtained from the office of the Court or from the applicant or the applicant's solicitor.

Queries to the applicant's solicitor should be directed towards Susan Miller.

SUSAN MILLER, Solicitor for the Applicant.

aw5996

Advertisement of Application for Putting Company into Liquidation

Take notice that on the 8th day of July 1998, an application for putting **KT Footwear Limited** into liquidation by the High Court was filed in the High Court at Auckland.

The application is to be heard before the High Court at Auckland on Thursday, the 24th day of September 1998 at 10.45 a.m.

Any person, other than the defendant company, who wishes to appear on the hearing of the application must file an appearance not later than the second working day before that day.

The applicant is **Fern Country Leathers Limited** of Auckland, whose address for service is the offices of its solicitors, Raymond S. Walker, Level Eight, 43 High Street, Auckland.

Further particulars may be obtained from the office of the Court or from the applicant or the applicant's solicitor.

RAYMOND S. WALKER, Solicitor for the Applicant.

aw5969

Advertisement of Application for Putting Company into Liquidation

Take notice that on the 7th day of August 1998, an application for putting **Cutter Douglas Architects Limited** into liquidation by the High Court was filed in the High Court at Christchurch.

The application is to be heard before the High Court at Christchurch on the 7th day of September 1998 at 9.30 a.m.

Any person, other than the defendant company, who wishes

to appear on the hearing of the application must file an appearance not later than the second working day before that day.

The applicants are **William Ian Wood** and **Murray John Loy Meyer** (trading as **Ian Wood Associates**), whose address for service is at the offices of Wynn Williams & Co, Solicitors, Seventh Floor, BNZ House, 129 Hereford Street, Christchurch.

Further particulars may be obtained from the office of the Court or from the applicants or the applicants' solicitor.

P. F. WHITESIDE, Solicitor for the Applicants.

aw5970

Advertisement of Application for Putting Incorporated Society into Liquidation

Pursuant to the Judicature Act 1908

Take notice that on the 15th day of July 1998, an application for putting **Wakatipu Club Incorporated** into liquidation by the High Court was filed in the High Court at Invercargill.

The application is to be heard before the High Court at Invercargill on the 21st day of September 1998 at 10.00 a.m.

Any person, other than the defendant society, who wishes to appear on the hearing of the application must file an appearance not later than the second working day before that day.

The applicant is the **Wakatipu Club Incorporated**, whose address for service is at the offices of Messrs Berry & Co, Solicitors, corner of Camp and Shotover Streets, Queenstown.

Further particulars may be obtained from the office of the Court or from the applicant or the applicant's solicitor.

S. STAMERS-SMITH, Solicitor for the Applicant.

aw5971

Advertisement of Application for Putting Company into Liquidation

M. No. 322/98

Take notice that on the 12th day of August 1998, an application for the appointment of a liquidator and for putting **Future Card Management Limited** into liquidation by the High Court was filed in the High Court at Wellington.

The application is to be heard before the High Court at Wellington on the 14th day of September 1998 at 10.00 a.m.

Any person, other than the defendant company, who wishes to appear on the hearing of the application must file an appearance not later than the second working day before that day.

The applicant is **Buddle Findlay**, whose address for service is at the offices of Buddle Findlay, Solicitors, Level Seventeen, BNZ Centre, 1 Willis Street, Wellington (*Attention: G. C. Thomas*).

Documents for service on the plaintiff may be left at that address for service or may be:

- (a) Posted to the solicitor at P.O. Box 2694, Wellington; or
- (b) Left for the solicitor at a document exchange for directions to D.X. S.P. 20-201, Wellington.

Further particulars may be obtained from the office of the Court or from the applicant or the applicant's solicitor.

C. S. CHAPMAN, Solicitor for the Applicant.

aw6033

Advertisement of Application for Putting Company into Liquidation

M. No. 315/98

Take notice that on the 4th day of August 1998, an application for putting **Bogarts Pizza Limited** into liquidation by the High Court was filed in the High Court at Wellington.

The application is to be heard before the High Court at Wellington on Monday, the 7th day of September 1998 at 10.00 a.m.

Any person, other than the defendant company, who wishes to appear on the hearing of the application must file an appearance not later than the second working day before that day.

The applicant is **The Radio Network of New Zealand Limited**, whose address for service is at the offices of David Nicoll, Barrister and Solicitor, 369 Parnell Road, Parnell, Auckland (P.O. Box 37-336, Parnell, Auckland).

Further particulars may be obtained from the office of the Court or from the applicant or the applicant's solicitor.

DAVID NICOLL, Solicitor for the Applicant.

aw6034

Advertisement of Application for Putting Company into Liquidation

Take notice that on Monday, the 10th day of August 1998, an application for putting into liquidation **Waipuna International Limited** by the High Court was filed in the High Court at Auckland.

The application is to be heard before the High Court at Auckland on the 10th day of September 1998 at 10.45 a.m.

Any person, other than the defendant company, who wishes to appear on the hearing of the application must file an appearance not later than the second working day before that day.

The applicant is **Glen Lyon Properties Limited**, whose address for service is at the offices of Timpany Walton, Lawlink, Solicitors, 11 Strathallan Street, Timaru.

Further particulars may be obtained from the office of the Court or from the applicant or the applicant's solicitor.

DAVID BRUCE TIMPANY, Solicitor for the Applicant.

aw6059

Advertisement of Application for Putting Company into Liquidation

M. No. 1387/98

Take notice that on the 6th day of August 1998, an application for putting **Trailer Sign Rentals Limited** into liquidation by the High Court was filed in the High Court at Auckland.

The application is to be heard before the High Court at Auckland on the 10th day of September 1998 at 10.00 a.m.

Any person, other than the defendant company, who wishes to appear on the hearing of the application must file an appearance not later than the second working day before that day.

The applicant is **Charles Ian Redgrave**, whose address for service is Dail Michael John Jones, Solicitor, care of Dail

Jones, Solicitor, 250 Main Road (P.O. Box 122 or D.X. D.P. 90-502), Kumeu (*Officer for Inquiries: Dail Jones*).

Further particulars may be obtained from the office of the Court or from the applicant or the applicant's solicitor.

DAIL JONES, Solicitor for the Applicant.

aw6063

Advertisement of Application for Putting Company into Liquidation

M. No. 919/98

Take notice that on the 5th day of June 1998, an application for putting **Rix New Zealand Limited** into liquidation by the High Court was filed in the High Court at Auckland.

The application is to be heard before the High Court at Auckland on the 24th day of September 1998 at 10.00 a.m.

Any person, other than the defendant company, who wishes to appear on the hearing of the application must file an appearance not later than the second working day before that day.

The applicant is **Martelli McKegg Wells & Cormack**, whose address for service is at its offices, Fourteenth Floor, Arthur Andersen Tower, National Bank Centre, 209 Queen Street, Auckland (*Counsel Acting: L. K. O'Leary*).

Further particulars may be obtained from the office of the Court or from the applicant or the applicant's solicitor.

M. C. M. CORMACK, Solicitor for the Applicant.

aw6114

Advertisement of Application for Putting Company into Liquidation by the Court

M. No. 42/98

Take notice that on the 4th day of August 1998, an application for putting **Eastern Haulage Limited** into liquidation by the High Court was filed in the High Court at Whangarei.

The application is to be heard before the High Court at Whangarei on Monday, the 14th day of September 1998 at 10.00 a.m.

Any person, other than the defendant company, who wishes to appear on the hearing of the application must file an appearance not later than the second working day before that day.

The applicant is **Caltex New Zealand Limited**, whose address for service is at the offices of Debtor Management (N.Z.) Limited, Level Two, 2 Ryan Place, Manukau City (P.O. Box 76-391, Manukau City), Auckland. Facsimile: (09) 263 7637.

Further particulars may be obtained from the office of the Court or from the applicant or the applicant's solicitor.

JEFFREY G. USSHER, Solicitor for the Applicant.

aw6115

Advertisement of Application for Putting Company into Liquidation

Take notice that on the 19th day of June 1998, an application for putting **Deco Bay Limited** into liquidation by the High Court was filed in the High Court at Napier.

The application is to be heard before the High Court at Napier on the 24th day of September 1998 at 10.00 a.m.

Any person, other than the defendant company, who wishes to appear on the hearing of the application must file an

appearance not later than the second working day before that day.

The applicant is **Mutual Leasing Limited** (trading as **Avis Lease**), whose address for service is at the offices of Messrs Duggan & Murphy, Solicitors, 101 Main Highway (P.O. Box 11-145), Ellerslie, Auckland.

Further particulars may be obtained from the office of the Court or from the applicant or the applicant's solicitor.

KEITH HARRY GODDARD, Solicitor for the Applicant.

aw6117

Advertisement of Application for Liquidation of Company by the Court

Take notice that on the 3rd day of August 1998, an application for the liquidation of **General Capital and Commerce Limited** by the High Court was filed in the High Court at Auckland.

The application is to be heard before the High Court at Auckland on Thursday, the 3rd day of September 1998 at 10.45 a.m.

Any person, other than the defendant company, who wishes to appear on the hearing of the application must file an appearance not later than the second working day before that day.

The applicant is **John Lawrence Vague** and **Graeme George McDonald** as liquidators for **Vendit Marketing Limited** (in liquidation), whose address for service is at the offices of Messrs Jackson Russell, Third Floor, KPMG Centre, 9 Princes Street, Auckland (*Attention: David France*).

Further particulars may be obtained from the office of the Court or from the applicant or the applicant's solicitor.

R. N. T. NORRIS, Solicitor for the Applicant.

aw6118

Advertisement of Application to Putting Company into Liquidation by the Court

M. No. 1415/98

Take notice that on the 11th day of August 1998, an application to put **Royal Jelly New Zealand Limited** into liquidation was filed by the High Court at Auckland.

The application is to be heard before the High Court at Auckland on Thursday, the 10th day of September 1998 at 10.00 a.m.

Any person, other than the defendant company, who wishes to appear on the hearing of the application must file an appearance not later than the second working day before that day.

The applicant is **Active Plastics Limited**, whose address is 69 Ellis Street, Frankton, Hamilton.

The applicant's solicitor is Peter Rayner Kellaway, whose address is care of Almao Kellaway, Solicitors, P.O. Box 19-173, Hamilton.

The applicant's address for service is the offices of Messrs Almao Kellaway, Fifth Floor, NZI Building, Garden Place, Hamilton.

The statement of claim and the verifying affidavit may be inspected at the office of the Court or at the applicant's address for service.

Further particulars may be obtained from the office of the Court or from the applicant or the applicant's solicitor.

P. R. KELLAWAY, Solicitor for the Applicant.

aw6138

Advertisement of Application for Putting Company into Liquidation

Take notice that on the 12th day of August 1998, an application for putting **Camatos Holdings Limited** into liquidation by the High Court was filed in the High Court at Auckland.

The application is to be heard before the High Court at Auckland on the 10th day of September 1998 at 10.00 a.m.

Any person, other than the defendant company, who wishes to appear on the hearing of the application must file an appearance not later than the second working day before that day.

The applicant is **Neil Civil Engineering (1992) Limited**, whose address for service is Chamberlains, Level Nine, Arthur Andersen Tower, National Bank Centre, 209 Queen Street, Auckland (*Attention: L. Symons*).

Further particulars may be obtained from the office of the Court or from the applicant or the applicant's solicitor.

N. J. PORTER, Solicitor for the Applicant.

aw6140

Advertisement of Application for Putting Company into Liquidation

M. No. 1414/98

Take notice that on the 10th day of August 1998, an application for putting **Rathgar Enterprises Limited** into liquidation by the High Court was filed in the High Court at Auckland.

The application is to be heard before the High Court at Auckland on the 10th day of September 1998 at 10.00 a.m.

Any person, other than the defendant company, who wishes to appear on the hearing of the application must file an appearance not later than the second working day before that day.

The applicants are **C. E. Thackwray, C. D. Thackwray and P. M. Dodd** as trustees of the **Thackwray Family Trust**, whose address for service is at the offices of Grove Darlow & Partners, Solicitors, Level Eleven, BNZ Tower, 125 Queen Street, Auckland 1001.

Further particulars including the statement of claim and verifying affidavit may be obtained from the office of the Court or from the applicants or the applicants' solicitor at the address for service shown above.

PAUL JOHN DALE, Solicitor for the Applicants.

aw6142

Advertisement of Application for Putting Company into Liquidation

M. No. 1411/98

Take notice that on the 10th day of August 1998, an application for putting **G.S. Lintott & Company Limited** into liquidation by the High Court was filed in the High Court at Auckland.

The application is to be heard before the High Court at Auckland on the 10th day of September 1998 at 10.45 a.m.

Any person, other than the defendant company, who wishes

to appear on the hearing of the application must file an appearance not later than the second working day before that day.

The applicant is **A.C. Nielsen (NZ) Limited**, whose address for service is at the offices of Rudd Watts & Stone, Solicitors, Twenty-fourth Floor, Bank of New Zealand Tower, 125 Queen Street (P.O. Box 3798), Auckland.

Further particulars may be obtained from the office of the Court or from the applicant or the applicant's solicitor.

G. M. SANDELIN, Solicitor for the Applicant.

aw6173

Advertisement of Application for Putting Company into Liquidation

M. No. 297/98

Take notice that on the 30th day of July 1998, an application for putting **N.EU. New Zealand Europe Group Limited** into liquidation by the High Court was filed in the High Court at Wellington.

The application is to be heard before the High Court at Wellington on the 7th day of September 1998 at 10.00 a.m.

Any person, other than the defendant company, who wishes to appear on the hearing of the application must file an appearance not later than the second working day before that day.

The applicant is **Delta Service SRL**, whose address for service is at the offices of Kensington Swan, Solicitors, 22 Fanshawe Street, Auckland.

Further particulars may be obtained from the office of the Court or from the applicant or the applicant's solicitor.

D. J. CHISHOLM, Solicitor for the Applicant.

aw6119

Advertisement of Application for Putting Company into Liquidation

Take notice that on the 10th day of August 1998, an application for putting **Pene Brothers Limited** into liquidation by the High Court was filed in the High Court at Wellington.

The application is to be heard before the High Court at Wellington on Monday, the 7th day of September 1998 at 10.00 a.m.

Any person, other than the defendant company, who wishes to appear on the hearing of the application must file an appearance not later than the second working day before that day.

The applicant is **Allied Milburn Limited** (trading as **Readimix Concrete Hutt Valley**), whose address for service is care of Preston Russell, Solicitors, 92 Spey Street, Invercargill. Telephone: (03) 214 4626. Facsimile: (03) 218 9536.

Further particulars may be obtained from the office of the Court or from the applicant or the applicant's solicitor.

J. N. P. YOUNG, Solicitor for the Applicant.

aw6120

APPOINTMENT AND RELEASE OF LIQUIDATORS

Appointment of Liquidator

The official assignee was appointed liquidator of the following companies on:

13 August 1998

- Evans Pneumatics Limited** (in liquidation).
- Kite Moana Oysters Limited** (in liquidation).
- Account Investment Limited** (in liquidation).
- Kusan Corporation Limited** (in liquidation).
- Xedos Distribution Limited** (in liquidation).
- Instore Interiors Limited** (in liquidation).
- Mobile Marine Limited** (in liquidation).

20 August 1998

- Burslem Group Limited** (in liquidation).
- Ganley Refrigeration Services Limited** (in liquidation).
- BGL International Limited** (in liquidation).
- Classic Bathrooms Limited** (in liquidation).

Address of Liquidator:

OFFICIAL ASSIGNEE.

New Zealand Insolvency and Trustee Service, Private Bag 3090, Hamilton. Telephone: (07) 839 5055. Facsimile: (07) 839 0388.

al6130

Appointment of Liquidator

The Charitable Trusts Act 1957 and the Companies Act 1993

The official assignee was appointed by the High Court as liquidator of the following trust on:

12 August 1998

- Te Puke Memorial Aquatic Centre Trust Board Incorporated** (in liquidation).

Address of Liquidator:

OFFICIAL ASSIGNEE.

New Zealand Insolvency and Trustee Service, Private Bag 3090, Hamilton. Telephone: (07) 839 5055. Facsimile: (07) 839 0388.

al6129

Appointment of Liquidator

Auckland

The official assignee at Auckland was appointed as liquidator of the following companies on:

13 August 1998

- Kiwi North Nine Limited** (in liquidation).
- Mobile Sawmillers Limited** (in liquidation).

Address of Liquidator:

OFFICIAL ASSIGNEE.

New Zealand Insolvency and Trustee Service, Private Bag 92-513, Wellesley Street, Auckland. Telephone: (09) 357 4141. Facsimile: (09) 357 1776.

al5989

About Communication Limited (in liquidation)

Notice of Appointment of Liquidator and Notice to Creditors to Prove Debts or Claims

Notice is hereby given that on the 9th day of August 1998, the above company passed a special resolution to be liquidated and appointed Curtis John Mountfort, chartered accountant of Auckland, as liquidator.

The liquidator fixes the 9th day of September 1998, as the day on or before the creditors of the company are to make their claims, and establish any priority their claims may have under section 312 of the Companies Act 1993, or to be excluded from the benefit of any distribution made before the claims made, as the case may be, or from objecting to the distribution.

Creditors and members may direct inquiries to the liquidator during normal business hours at the address stated below.

CURTIS JOHN MOUNTFORT, Liquidator.

Address for Service: Mountfort & Associates, Insolvency Specialists, P.O. Box 82-161, Auckland. Telephone: (09) 535 5675. Facsimile: (09) 535 5675.

al5997

Azalea Investments Limited and Global Construction Limited (both in liquidation)

Notice of Appointment of Liquidators

Notice is hereby given that the liquidation of the above-named companies commenced on the 13th day of August 1998, when the High Court, Auckland, appointed Brendon James Gibson and Stephen Mark Lawrence, joint and several liquidators, in accordance with section 241 (2) (c) of the Companies Act 1993.

Creditors and Members May Direct Their Inquiries to the Liquidators: Care of Ferrier Hodgson & Co, Level Sixteen, Southpac Tower, 45 Queen Street, Auckland (P.O. Box 982, Auckland). Telephone: (09) 307 7865. Facsimile: (09) 377 7794.

All Inquiries to: Margaret Moynahan.

al5998

Notice of Appointment of Liquidator

In the matter of section 241 (2) (a) of the Companies Act 1993, and in the matter of **Gilando Enterprises Limited** and **Omega Chi Holdings Limited** (both in liquidation):

Notice is hereby given that on the 17th day of August 1998, I was appointed liquidator of the above companies which are being wound up voluntarily.

I now fix the 30th day of September 1998, as the day on or before which the creditors of the companies are to prove their debts or claims, and to establish any title they may have to priority, or to be excluded from the benefit of any distribution made before the debts are proved or, as the case may be, from objecting to any distributions.

DAVID NICOLL, Liquidator.

Address of Liquidator: 369 Parnell Road (P.O. Box 37-336), Auckland 1. Telephone: (09) 358 4975.

al5992

Notice of Appointment of Liquidator

In the matter of section 241 (2) (a) of the Companies Act 1993, and in the matter of **Maritime Duty Free Sales Limited** (in liquidation):

Notice is hereby given that on the 19th day of August 1998, I was appointed liquidator of the above company which is being wound up voluntarily.

I now fix the 30th day of September 1998, as the day on or before which the creditors of the company are to prove their debts or claims, and to establish any title they may have to priority, or to be excluded from the benefit of any distribution made before the debts are proved or, as the case may be, from objecting to any distributions.

DAVID NICOLL, Liquidator.

Address of Liquidator: 369 Parnell Road (P.O. Box 37-336), Auckland 1. Telephone: (09) 358 4975.

al6136

Notice of Appointment of Liquidators

In the matter of section 255 (2) (a) of the Companies Act 1993, and in the matter of **Nakano Construction (NZ) Limited** (in liquidation):

Notice is hereby given that by special resolution passed on the 18th day of August 1998, in accordance with section 241 (2) (a) of the Companies Act 1993, the company was placed in liquidation and Laurence George Chilcott and Peter Charles Chatfield, chartered accountants of Auckland, were appointed joint and several liquidators.

Dated at Auckland this 18th day of August 1998.

L. G. CHILCOTT, Joint and Several Liquidator.

Any Inquiries in This Matter Should be Addressed to the Liquidators at the Offices of: Smith Chilcott, Chartered Accountants, P.O. Box 5545, Auckland. Telephone: (09) 379 8035. Facsimile: (09) 307 8892.

al6003

Notice of Appointment of Liquidator

In the matter of section 255 (2) (a) of the Companies Act 1993, and in the matter of **Delos Enterprises Limited** (in liquidation):

Notice is hereby given that by special resolution passed on the 18th day of August 1998, in accordance with section 241 (2) (a) of the Companies Act 1993, the company was placed in liquidation and Laurence George Chilcott, chartered accountant of Auckland, was appointed liquidator.

A certificate of solvency, pursuant to section 243 (8) of the Companies Act 1993, has been completed by the directors.

Dated at Auckland this 18th day of August 1998.

L. G. CHILCOTT, Liquidator.

Any Inquiries in This Matter Should be Addressed to the Liquidator at the Offices of: Smith Chilcott, Chartered Accountants, P.O. Box 5545, Auckland. Telephone: (09) 379 8035. Facsimile: (09) 307 8892.

al6005

Notice of Appointment of Liquidator

In the matter of section 255 (2) (a) of the Companies Act 1993, and in the matter of **Independent Taverns Limited** (in liquidation):

Notice is hereby given that by special resolution passed on the 18th day of August 1998, in accordance with section 241 (2) (a) of the Companies Act 1993, the company was placed in liquidation and Laurence George Chilcott,

chartered accountant of Auckland, was appointed liquidator.

A certificate of solvency, pursuant to section 243 (8) of the Companies Act 1993, has been completed by the directors.

Dated at Auckland this 18th day of August 1998.

L. G. CHILCOTT, Liquidator.

Any Inquiries in This Matter Should be Addressed to the Liquidator at the Offices of: Smith Chilcott, Chartered Accountants, P.O. Box 5545, Auckland. Telephone: (09) 379 8035. Facsimile: (09) 307 8892.

al6007

Notice of Appointment of Liquidator

In the matter of section 255 (2) (a) of the Companies Act 1993, and in the matter of **Nordica Investments Limited** (in liquidation):

Notice is hereby given that by special resolution passed on the 18th day of August 1998, in accordance with section 241 (2) (a) of the Companies Act 1993, the company was placed in liquidation and Laurence George Chilcott, chartered accountant of Auckland, was appointed liquidator.

A certificate of solvency, pursuant to section 243 (8) of the Companies Act 1993, has been completed by the directors.

Dated at Auckland this 18th day of August 1998.

L. G. CHILCOTT, Liquidator.

Any Inquiries in This Matter Should be Addressed to the Liquidator at the Offices of: Smith Chilcott, Chartered Accountants, P.O. Box 5545, Auckland. Telephone: (09) 379 8035. Facsimile: (09) 307 8892.

al6009

Notice of Appointment of Liquidator

In the matter of section 255 (2) (a) of the Companies Act 1993, and in the matter of **Moonshine Enterprises Limited** (in liquidation):

Notice is hereby given that by special resolution passed on the 18th day of August 1998, in accordance with section 241 (2) (a) of the Companies Act 1993, the company was placed in liquidation and Laurence George Chilcott, chartered accountant of Auckland, was appointed liquidator.

A certificate of solvency, pursuant to section 243 (8) of the Companies Act 1993, has been completed by the directors.

Dated at Auckland this 18th day of August 1998.

L. G. CHILCOTT, Liquidator.

Any Inquiries in This Matter Should be Addressed to the Liquidator at the Offices of: Smith Chilcott, Chartered Accountants, P.O. Box 5545, Auckland. Telephone: (09) 379 8035. Facsimile: (09) 307 8892.

al6011

Notice of Appointment of Liquidator

In the matter of section 255 (2) (a) of the Companies Act 1993, and in the matter of **Sheehans Wines & Spirits Limited** (in liquidation):

Notice is hereby given that by special resolution passed on the 18th day of August 1998, in accordance with section 241 (2) (a) of the Companies Act 1993, the company was placed in liquidation and Laurence George Chilcott, chartered accountant of Auckland, was appointed liquidator.

A certificate of solvency, pursuant to section 243 (8) of the Companies Act 1993, has been completed by the directors.

Dated at Auckland this 18th day of August 1998.

L. G. CHILCOTT, Liquidator.

Any Inquiries in This Matter Should be Addressed to the Liquidator at the Offices of: Smith Chilcott, Chartered Accountants, P.O. Box 5545, Auckland. Telephone: (09) 379 8035. Facsimile: (09) 307 8892.

al6013

Notice of Appointment of Liquidators

In the matter of section 255 (2) (b) of the Companies Act 1993, and in the matter of **Hillcrest Construction Limited** (in receivership and in liquidation):

No. of Company: 562732.

Presented by: Deloitte Touche Tohmatsu, Chartered Accountants, P.O. Box 33, Auckland.

To: The Registrar of Companies, Auckland.

I, Rodney Gane Pardington, chartered accountant of Auckland, hereby give you notice that I have been appointed liquidator of Hillcrest Construction Limited by special resolution of the shareholders of the company on the 13th day of August 1998.

R. G. PARDINGTON, Liquidator.

al6021

K B J Devlin Limited (in liquidation)

Notice of Appointment of Liquidator

Hamish Alexander Scott, accountant of Christchurch, hereby gives public notice of his appointment and acceptance as liquidator.

The liquidation was commenced on the 15th day of August 1998 by a special resolution of the shareholders of K B J Devlin Limited (in liquidation), appointing Hamish Alexander Scott as liquidator.

Please Direct All Inquiries Regarding This Liquidation to: Hamish Alexander Scott, Scott Macdonald, Accountants, P.O. Box 33-007, Christchurch. Telephone: (03) 365 9021. Facsimile: (03) 365 9022.

This notice was inserted by:

SCOTT MACDONALD, Accountants of Christchurch.

al6024

Aero'port New Zealand Shuttle Express and Tours Limited (in liquidation) (formerly called Aero'port New Zealand Limited)

Notice of Appointment of Liquidator

Dennis Clifford Parsons, chartered accountant of Hamilton, was appointed liquidator of Aero'port New Zealand Shuttle Express and Tours Limited (in liquidation) (formerly called Aero'port New Zealand Limited) on the 13th day of August 1998, pursuant to section 241 (2) (a) of the Companies Act 1993.

Notice to Creditors to Prove Debts or Claims

Notice is given that the liquidators of Aero'port New Zealand Shuttle Express and Tours Limited (in liquidation) fix the 31st day of October 1998, as the day on or before which the creditors of the company are to make their claims, and to establish any priority their claims may have, under section 312 of the Companies Act 1993, or to be excluded from the benefit of any distribution made before their claims are made or, as the case may be, from objecting to any distribution.

Dated this 15th day of August 1998.

D. C. PARSONS, Liquidator.

The Address and Telephone Number to Which, During Normal Business Hours, Inquiries May be Directed By a Creditor or Member: Indepth Forensic, Chartered Accountants P.O. Box 278, Hamilton. Telephone: (07) 838 2265. Facsimile: (07) 838 2264.

al5982

French (Asia Pacific) Limited (in receivership and in liquidation)

Notice of Appointment of Liquidators

Notice is hereby given that in accordance with section 241 (2) (c) of the Companies Act 1993, the High Court of Auckland on the 13th day of August 1998, appointed John Lawrence Vague and Graeme George McDonald, chartered accountants of Auckland, jointly and severally as liquidators of the above-named company.

JOHN L. VAGUE, Liquidator.

Officer for Inquiries: Michelle Jacques.

Date of Liquidation: 13 August 1998.

Address for Service: John Vague & Associates, P.O. Box 6092, Wellesley Street Post Office, Auckland. Telephone: (09) 303 0506. Facsimile: (09) 303 0508.

al5983

Seven Traders Limited (in liquidation) (formerly known as Travel Brands Limited)

Notice of Appointment of Liquidators and Notice to Creditors to Prove Debts or Claims

Notice is hereby given that in accordance with section 241 of the Companies Act 1993, the shareholders of the above-named company on the 18th day of August 1998, appointed John Lawrence Vague and Graeme George McDonald, chartered accountants of Auckland, jointly and severally as liquidators of the above-named company.

The undersigned does hereby fix the 30th day of September 1998, as the day on or before which the creditors of the company are to prove their debts or claims, and to establish any title they may have to priority under section 312 of the Companies Act 1993, or to be excluded from the benefit of any distribution made before the debts are proved or, as the case may be, from objecting to the distribution.

JOHN L. VAGUE, Liquidator.

Officer for Inquiries: John Whittfield.

Date of Liquidation: 18 August 1998.

Address for Service: John Vague & Associates, P.O. Box 6092, Wellesley Street Post Office, Auckland. Telephone: (09) 303 0506. Facsimile: (09) 303 0508.

al6057

Briteway Industries (Auckland) Limited (in liquidation)

Notice of Appointment of Liquidators and Notice to Creditors to Prove Debts or Claims

Notice is hereby given that in accordance with section 241 of the Companies Act 1993, the High Court at Napier on the 20th day of August 1998, appointed John Lawrence Vague and Graeme George McDonald, chartered accountants of Auckland, jointly and severally as liquidators of the above-named company.

The undersigned does hereby fix the 24th day of September 1998, as the day on or before which the creditors of the company are to prove their debts or claims, and to establish any title they may have to priority under section 312 of the

Companies Act 1993, or to be excluded from the benefit of any distribution made before the debts are proved or, as the case may be, from objecting to the distribution.

JOHN L. VAGUE, Liquidator.

Officer for Inquiries: Nicola Hamill.

Date of Liquidation: 20 August 1998.

Address for Service: John Vague & Associates, P.O. Box 6092, Wellesley Street Post Office, Auckland. Telephone: (09) 303 0506. Facsimile: (09) 303 0508.

al6134

Chelsea First National Limited (in liquidation)

Notice of Appointment of Liquidators

Notice is hereby given that on the 15th day of August 1998, John Robert Buchanan and Stephen Glenn Hotchin, chartered accountants of Auckland, were appointed liquidators of Chelsea First National Limited (in liquidation).

Any members or creditors should make inquiry to our office as below.

S. G. HOTCHIN, Joint Liquidator.

Address of Liquidators: Buchanan & Associates, P.O. Box 33-315, Takapuna, Auckland. Telephone: (09) 486 0286. Facsimile: (09) 486 0643.

al6055

Wine Castle Limited (in liquidation)

Notice of Appointment of Liquidators

By resolution of the shareholders, pursuant to section 241 (2) of the Companies Act 1993, dated the 7th day of August 1998, John Robert Buchanan and Stephen Glenn Hotchin, chartered accountants of Auckland, were appointed liquidators.

J. R. BUCHANAN, Joint Liquidator.

The Address and Telephone Number to Which, During Normal Business Hours, Inquiries May be Directed by a Creditor or Member: Buchanan & Associates, P.O. Box 33-315, Takapuna, Auckland. Telephone: (09) 486 0286. Facsimile: (09) 486 0643.

al6056

Auckland Building Services Limited (in liquidation) and Halford Refrigeration Limited (in liquidation)

Notice of Appointment of Liquidators

Notice is hereby given that, pursuant to section 241 (2) (c) of the Companies Act 1993, Colin Thomas McCloy, chartered accountant of Auckland and Vivian Judith Fatupaito, insolvency practitioner of Auckland, were appointed joint and several liquidators of Auckland Building Services Limited and Halford Refrigeration Limited.

The liquidation commenced on the 20th day of August 1998.

Inquiries May Be Directed By a Creditor or Shareholder of the Company During Normal Business Hours to: Kevin Lee or Craig Sanson at PricewaterhouseCoopers, Auckland, or on Telephone No.: (09) 355 8000.

Notice is also given that the liquidators hereby fix the 20th day of November 1998, as the day on or before which the creditors of the companies are to make their claims and

to establish any priority their claims may have under section 312 of the Companies Act 1993.

Dated this 21st day of August 1998.

VIVIAN JUDITH FATUPAITO, Joint and Several Liquidators.

Address for Service: PricewaterhouseCoopers, Private Bag 92-162, Auckland.

al6058

Dress For Less Limited (in receivership and in liquidation)

Notice of Appointment of Liquidators

Jeffrey Philip Meltzer and Grant Bryan Charles Rae, insolvency practitioners, were appointed joint and several liquidators of Dress For Less Limited (in receivership and in liquidation) on the 18th day of August 1998, pursuant to section 241 (2) (a) of the Companies Act 1993.

Notice to Creditors to Prove Debts or Claims

Notice is given that the liquidators of Dress For Less Limited (in receivership and in liquidation), fixes the 30th day of September 1998, as the day on or before which the creditors of the company are to make their claims, and to establish any priority their claims may have, under section 312 of the Companies Act 1993, or to be excluded from the benefit of any distribution made before their claims are made or, as the case may be, from objecting to any distribution.

Dated this 24th day of August 1998.

J. P. MELTZER, Joint Liquidator.

Officer for Inquiries: Grant Rae.

The Address and Telephone Number to Which, During Normal Business Hours, Inquiries May be Directed by a Creditor or Member: Jeff Meltzer & Associates, Chartered Accountants, P.O. Box 6302, Wellesley Street, Auckland. Telephone: (09) 357 6150. Facsimile: (09) 357 6152.

al6135

Nelson Battery Services Limited (in liquidation) CH. 657495

Notice of Appointment of Liquidator

Pursuant to Section 255 (2) (a) of the Companies Act 1993

Notice is hereby given that by entry in its minute book on the 21st day of August 1998, the company passed the following special resolutions:

1. That the company cannot by reason of its liabilities continue and that the company should therefore be liquidated.
2. That Mr Richard Alfred Jenkins, chartered accountant of Nelson, be appointed liquidator of the company.

Pursuant to section 12 of the Companies Act 1993 Liquidation Regulations 1994, notice is hereby given that the final date by which creditors can apply to have their claims admitted is the 11th day of September 1998.

RICHARD JENKINS, Liquidator.

The Liquidator May be Contacted at: VBM Insolvency, 38 Halifax Street (P.O. Box 210), Nelson. Telephone: (03) 548 1549. Facsimile: (03) 546 9504.

al6137

Kahury Holdings Limited (in liquidation)
(formerly **Rossini's (N.Z.) Fine Foods Limited**)

Notice of Appointment of Liquidator

Notice is hereby given that the liquidation of Kahury Holdings Limited (formerly Rossini's (N.Z.) Fine Foods Limited) commenced on Thursday, the 20th day of August 1998, when the members appointed Murray George Allott, chartered accountant of 13 Woodford Terrace, Fendalton, Christchurch, as liquidator in accordance with section 241 (2) of the Companies Act 1993, by the passing of a resolution by entry in the company minute book.

Any inquiries by creditors or shareholders may be directed to the liquidator.

MURRAY G. ALLOTT, Liquidator.

Address of Liquidator: 13 Woodford Terrace, Fendalton (P.O. Box 8666), Christchurch. Telephone: (03) 351 7794. Facsimile: (03) 351 4600.

al6144

Summersun Nurseries Limited (in liquidation)

Notice of Appointment of Liquidator

The Companies Act 1993

Notice is hereby given that on the 19th day of August 1998, it was resolved by special resolution of shareholders,

pursuant to section 241 (2) (a) of the Companies Act 1993, that Summersun Nurseries Limited (in liquidation) be liquidated and that Anthony John McCullagh, chartered accountant of Auckland, be appointed liquidator for that purpose.

Notice to Creditors to Prove Debts or Claims

Notice is given that the liquidator fixes the 30th day of September 1998, as the day on or before the creditors of the above-mentioned company are to make their claims, and establish any priority their claims may have under section 286, or to be excluded from the benefit of any distribution made before the claims made, as the case may be, from objecting to the distribution.

Creditors and members may direct inquiries to the liquidator during normal business hours at the address stated below.

The Contact Address is: P.O. Box 3678, Shortland Street, Auckland (Attention: A. J. McCullagh). Telephone: (09) 302 0521.

al6145

MEETINGS AND LAST DATES BY WHICH TO PROVE DEBTS OR CLAIMS

Notice to Creditors to Claim

In the matter of the Companies Act 1993, and in the matter of **Trans Capital Limited** (in liquidation):

Notice is hereby given that the liquidator of Trans Capital Limited (in liquidation), does hereby fix the 17th day of September 1998, as the day on or before which the creditors of the company are to prove their debts or claims, and to establish any title they may have to priority under section 312 of the Companies Act 1993, or to be excluded from the benefit of any distribution made before the debts are proved or, as the case may be, from objecting to the distribution.

Dated this 19th day of August 1998.

JOHN MANAGH, Liquidator.

Address of Liquidator: Level Two, Bower House, 24 Bower Street (P.O. Box 1022), Napier. Telephone: (06) 835 6280. Facsimile: (06) 835 6280.

md5993

Notice to Creditors to Claim

In the matter of the Companies Act 1993, and in the matter of **Trans Capital (Euro) Limited** (in liquidation):

Notice is hereby given that the liquidator of Trans Capital (Euro) Limited (in liquidation), does hereby fix the 17th day of September 1998, as the day on or before which the creditors of the company are to prove their debts or claims, and to establish any title they may have to priority under section 312 of the Companies Act 1993, or to be excluded from the benefit of any distribution made before the debts are proved or, as the case may be, from objecting to the distribution.

Dated this 19th day of August 1998.

JOHN MANAGH, Liquidator.

Address of Liquidator: Level Two, Bower House,

24 Bower Street (P.O. Box 1022), Napier. Telephone: (06) 835 6280. Facsimile: (06) 835 6280.

md5995

Nakano Construction (NZ) Limited
(in liquidation)

Notice of Meeting of Creditors

Pursuant to Section 243 of the Companies Act 1993

A meeting of creditors will be held at the offices of Smith Chilcott, First Floor, General Building, 29 Shortland Street, Auckland 1, on the 28th day of August 1998, commencing at 9.00 a.m.

The business to be transacted at the meeting of creditors shall be:

1. *Liquidators' Report:*

To consider the liquidators' report containing a statement of the company's affairs.

2. *Appointment of Liquidators:*

To consider whether to make an application to the Court for the appointment of a liquidator in place of the liquidators so appointed.

3. *Conduct of the Liquidation:*

To consider whether the liquidators should be asked to have regard to the views, if any, of creditors in conducting the liquidation.

4. *Liquidation Committee:*

To consider whether a liquidation committee be appointed and, if so, to appoint the members of that committee.

Dated at Auckland this 18th day of August 1998.

L. G. CHILCOTT, Liquidator.

md6001

Notice to Creditors to Claim

In the matter of the Companies Act 1993 Liquidation Regulations 1994, and in the matter of **Nakano Construction (NZ) Limited** (in liquidation):

We, Laurence George Chilcott and Peter Charles Chatfield, joint and several liquidators of the above company, hereby fix the 20th day of September 1998, as the date on or before which the creditors of the company are to make their claims, and to establish any priority their claims may have under section 312 of the Companies Act 1993.

Dated at Auckland this 18th day of August 1998.

L. G. CHILCOTT, Joint and Several Liquidator.

Any Inquiries in This Matter Should be Addressed to the Liquidator at the Offices of the Liquidators: Smith Chilcott, Chartered Accountants, P.O. Box 5545, Auckland. Telephone: (09) 379 8035. Facsimile: (09) 307 8892.

md6004

Notice to Creditors to Claim

In the matter of the Companies Act 1993 Liquidation Regulations 1994, and in the matter of **Delos Enterprises Limited** (in liquidation):

I, Laurence George Chilcott, liquidator of the above company, hereby fix the 20th day of September 1998, as the date on or before which the creditors of the company are to make their claims, and to establish any priority their claims may have under section 312 of the Companies Act 1993.

Dated at Auckland this 18th day of August 1998.

L. G. CHILCOTT, Liquidator.

Any Inquiries in This Matter Should be Addressed to the Liquidator at the Offices of the Liquidators: Smith Chilcott, Chartered Accountants, P.O. Box 5545, Auckland. Telephone: (09) 379 8035. Facsimile: (09) 307 8892.

md6006

Notice to Creditors to Claim

In the matter of the Companies Act 1993 Liquidation Regulations 1994, and in the matter of **Independent Taverns Limited** (in liquidation):

I, Laurence George Chilcott, liquidator of the above company, hereby fix the 20th day of September 1998, as the date on or before which the creditors of the company are to make their claims, and to establish any priority their claims may have under section 312 of the Companies Act 1993.

Dated at Auckland this 18th day of August 1998.

L. G. CHILCOTT, Liquidator.

Any Inquiries in This Matter Should be Addressed to the Liquidator at the Offices of the Liquidators: Smith Chilcott, Chartered Accountants, P.O. Box 5545, Auckland. Telephone: (09) 379 8035. Facsimile: (09) 307 8892.

md6008

Notice to Creditors to Claim

In the matter of the Companies Act 1993 Liquidation Regulations 1994, and in the matter of **Nordica Investments Limited** (in liquidation):

I, Laurence George Chilcott, liquidator of the above company, hereby fix the 20th day of September 1998, as the date on or before which the creditors of the company are to make their claims, and to establish any priority their

claims may have under section 312 of the Companies Act 1993.

Dated at Auckland this 18th day of August 1998.

L. G. CHILCOTT, Liquidator.

Any Inquiries in This Matter Should be Addressed to the Liquidator at the Offices of the Liquidators: Smith Chilcott, Chartered Accountants, P.O. Box 5545, Auckland. Telephone: (09) 379 8035. Facsimile: (09) 307 8892.

md6010

Notice to Creditors to Claim

In the matter of the Companies Act 1993 Liquidation Regulations 1994, and in the matter of **Moonshine Enterprises Limited** (in liquidation):

I, Laurence George Chilcott, liquidator of the above company, hereby fix the 20th day of September 1998, as the date on or before which the creditors of the company are to make their claims, and to establish any priority their claims may have under section 312 of the Companies Act 1993.

Dated at Auckland this 18th day of August 1998.

L. G. CHILCOTT, Liquidator.

Any Inquiries in This Matter Should be Addressed to the Liquidator at the Offices of the Liquidators: Smith Chilcott, Chartered Accountants, P.O. Box 5545, Auckland. Telephone: (09) 379 8035. Facsimile: (09) 307 8892.

md6012

Notice to Creditors to Claim

In the matter of the Companies Act 1993 Liquidation Regulations 1994, and in the matter of **Sheehans Wines & Spirits Limited** (in liquidation):

I, Laurence George Chilcott, liquidator of the above company, hereby fix the 20th day of September 1998, as the date on or before which the creditors of the company are to make their claims, and to establish any priority their claims may have under section 312 of the Companies Act 1993.

Dated at Auckland this 18th day of August 1998.

L. G. CHILCOTT, Liquidator.

Any Inquiries in This Matter Should be Addressed to the Liquidator at the Offices of the Liquidators: Smith Chilcott, Chartered Accountants, P.O. Box 5545, Auckland. Telephone: (09) 379 8035. Facsimile: (09) 307 8892.

md6014

AJ & NU Dobbyn Limited (in liquidation)
(trading as **Jims Place**)**Notice to Creditors to Claim**

We notify that the 18th day of September 1998 is the day on or before which the creditors of the above company are to make their claims and to establish any priority their claims may have under section 286 of the Companies Act 1955, or to be excluded from the benefit of any distribution made before their claims are made, or from objecting to the distribution.

Creditors or members may contact Grace Neal at KPMG, 135 Victoria Street (P.O. Box 996), Wellington.

Dated this 18th day of August 1998.

JOHN DRAGE, Liquidator.

md6020

REMOVALS

- | | |
|--|---|
| <p>AK District Registrar of Companies
Private Bag 92-513
Wellesley Street
Auckland
Telephone: (09) 357 1788
Facsimile: (09) 357 1785</p> <p>HN District Registrar of Companies
Private Bag 3090
Hamilton
Telephone: (07) 839 5055
Facsimile: (07) 839 4348</p> <p>NA District Registrar of Companies
Private Bag 6001
Napier
Telephone: (06) 835 7588
Facsimile: (06) 835 7421</p> | <p>WN District Registrar of Companies
Private Bag 5901
Lambton Quay
Wellington
Telephone: (04) 471 1028
Facsimile: (04) 473 2921</p> <p>CH District Registrar of Companies
Private Bag 4714
Christchurch
Telephone: (03) 366 4354
Facsimile: (03) 365 6445</p> <p>DN District Registrar of Companies
Private Bag 1927
Dunedin
Telephone: (03) 477 3722
Facsimile: (03) 477 5932</p> |
|--|---|

Corrigendum**Company Removals List Notice Revoked**

The below-named company was incorrectly removed from the Companies Register on the 11th day of August 1998:

Fuller Holdings Limited.

The company is now restored.

MARY HARRIS, Assistant Register of Companies.

ds6068

Notice of Intention to Remove Companies From the Register

I intend to remove the under-mentioned companies from the Register under section 318 of the Companies Act 1993.

I am satisfied that these companies have ceased to carry on business and there is no other reason for these companies to continue in existence.

Written objections to the company's removal, specifying the grounds relied on, can be made under section 321 of the Companies Act 1993. These must be delivered to the District Registrar of Companies at Hamilton within 20 working days of publication of this notice.

A and S Smyth Limited.
A M Walling Limited.
A.J & E.A Lanza Limited.
Airborne Investments Limited.
Allan Walker Limited.
Alpha Magnum Limited.
Andys Tamarillo Products Limited.
Aotearoa Valuation And Property Management Limited.
Armstrong Builders Limited.
ASI Horticulture Limited.
B.G. and H.E. Barrett Limited.
Baycare Medical Holdings 11 Limited.
Bernard Woods Process Division Limited.
Beverage Technologies Limited.
Bike & Recreation Distributors Limited.
Blackley Farms Limited.
Britton Housemovers Manawatu Limited.
Brownie And Roberts Management Services Limited.
C W Massey Limited.
Catamaran Enterprises Limited.
Catholic Engineering Limited.
Chris Ramsay Rally Sport Limited.
Citi Broker Insurances Limited.
Cliff Hayes Limited.

Colby Corporation Limited.
Computer Fix Limited.
Creative Designs Limited.
Curtain Textiles Limited.
David Jensen & Co Limited.
Davis Marketing Limited.
Deakin Bakery Limited.
Do It - Community Research And Management Limited.
Durham No. 6 Limited.
Eastcoasters Restaurant Limited.
Eldorado's Restaurant Limited.
Emerald Enterprises Limited.
Farmer Jones Co Limited.
Financial Freedom Seminar Centre Limited.
Fourtower Agencies NZ Limited.
Frankton Assembly Services Limited.
Funtec Products Limited.
Glas. Weld Systems NZ Limited.
Grant Norling Limited.
Grennan Holdings Limited.
Horomatangi Properties (No.42) Limited.
Host Clean Limited.
Humphrey Stone Limited.
Independent Rural Finance Limited.
Jag (1997) Limited.
Jag Distributors Limited.
Jasper Corporation Limited.
John F Jones Real Estate Limited.
John Sun International Trade Group Limited.
K & K Konsultants Limited.
K.G. & D.A. Heard Limited.
K.J. & M.U. Kusabs Plumbing Limited.
Kaimanawa Wood Products Rotorua Limited.
Kasel Investments Limited.
Keith Anderson Motors Limited.
Knight Euro-Lease Limited.
La Paz Limited.
Lake Properties Limited.
Laser Servicing Limited.
Lawnswood Limited.
Lex Moodie Computer Systems Limited.
Lifestyle Construction Limited.
Lorenz Holdings Limited.
M. and G.R. Jackson Limited.
Mark Rogers Builders Limited.
Marlin Marine Limited.
Maui Deer Farms Limited.
Maui Metals Limited.
Mehaney Taxation Services Limited.

Methleigh Farms Limited.
 Mexican Cantina Rotorua Limited.
 Mitchell's Distribution Limited.
 MMA Co., Limited.
 Montace Holdings Limited.
 Myko Holdings Limited.
 Network & System Automation Technologies Limited.
 New Plymouth Sportswear Limited.
 One Eyed Supporters & Promotions Co. Limited.
 Pacicon Limited.
 Page St Clothing Coy Limited.
 Paradise Investments Limited.
 Paraiso Properties Limited.
 Parcom Timber Limited.
 Petite Jewellers Limited.
 Phoenix Industries Limited.
 Piripaua Forests A10 Limited.
 Piripaua Forests A15 Limited.
 Piripaua Forests A2 Limited.
 Piripaua Forests A24 Limited.
 Piripaua Forests A46 Limited.
 Power Thrift Limited.
 Priestly Piggeries Limited.
 Propaganda Limited.
 Provincial Plumbers Limited.
 Pukeatua Holdings Limited.
 QV Entertainment Limited.
 R.U. Shifting Limited.
 Rainbow Hi Tech Limited.
 Rainbow Pearls Limited.
 Relwood Investments Limited.
 Right Time Charters Limited.
 Sanwood Holdings Limited.
 Sekap Contracts Limited.
 Sentry Hill Wines Limited.
 Sierra Builders Limited.
 Soil Sampling Services (NZ) Limited.
 Spring and Durham No.2 Limited.
 Standard Trader Limited.
 Steve Andersen Transport Limited.
 Synergy Card Limited.
 Tahlee Music Limited.
 Tahuna Transport Limited.
 Tainui Orchard Limited.
 Tam Cams Limited.
 Target Drilling Limited.
 Taupo Waste Removal Limited.
 Tauquip Chainsaws Limited.
 Tauranga Floating Hole In One Limited.
 Tauranga Tile Contracting Limited.
 Teleconnect Systems Limited.
 The Bolt Barn Limited.
 The Country Estate Limited.
 The Electronic Service Centre Limited.
 The Jolly Plunger Limited.
 Three-Way Taxis Limited.
 Total Air Systems Limited.
 Twin Peaks Lakeside Inn Pte. Limited.
 Two Tides Limited.
 Ultimate Finance Limited.
 W.D. & A.M. Graham Limited.
 W.M. & S.L. Armstrong Limited.
 Wave Industries Limited.
 Webster Bros City Markets (1993) Limited.
 Wilco Holdings Limited.
 Zalman and Linton Logging Limited.

Postal Address for Written Objections: The Registrar of Companies, Private Bag 3090, Hamilton.

NEVILLE HARRIS, Registrar of Companies.

ds6112

Notice of Intention to Remove Companies From the Register

I intend to remove the under-mentioned companies from the Register under section 318 of the Companies Act 1993.

I am satisfied that these companies have ceased to carry on business and there is no other reason for these companies to continue in existence.

Written objections to the company's removal, specifying the grounds relied on, can be made under section 321 of the Companies Act 1993. These must be delivered to the District Registrar of Companies at Hamilton within 20 working days of publication of this notice.

0800 Car Find Limited.
 2D Advertising Limited.
 3L Trading Co, Limited.
 568 Investments Limited.
 A & A Shum Limited.
 A & C Security Distributors Limited.
 A & I Consultants Limited.
 A Bell Marquee Hire Limited.
 A F Dexter Limited.
 A J W K Limited.
 A L Holdings Limited.
 Abacus Bookkeeping Centre Limited.
 Abas Company Limited.
 Abc Nappy Service Limited.
 Abl Holdings Limited.
 Able Transport (Wellington) Limited.
 Access Data Group Limited.
 Accrue Management Limited.
 Accudata Cleaning Products Limited.
 Adamas Jewellery Co Limited.
 Advance International Marketing (NZ) Limited.
 Affinity Holdings Limited.
 Agenda Company Limited.
 Agricultural Machinery Marketing (1998) Limited.
 Airborne Upholstery Limited.
 Airport Direct Shuttle Limited.
 Aklaw Number Seventy-Seven Limited.
 Albert Fanshawe 48 Limited.
 Alex Electrical Services Limited.
 Allen-Baines Sports Limited.
 Allford Auto Spares (Henderson) Limited.
 Alliance (NZ) Limited.
 Allied Auctions Limited.
 Allied Developments Limited.
 Alltype Roofing Limited.
 Altair Electronics Limited.
 American Tool Distributors Limited.
 Amersham Holdings Limited.
 Amtech Holdings (New Zealand) Limited.
 Amundsen Enterprises Limited.
 Ananias Developments Limited.
 Anatohia Seafoods Limited.
 Anne-Maree Rest Home Limited.
 Anorco Number Forty Seven Limited.
 Anytime Water Supply Services Limited.
 Appeal Homes Limited.
 Aps Management Services Limited.
 Aqua Moon 24 Limited.
 Aquaries Exim Limited.
 Aquarius Auto Wholesale Limited.
 Argyll Park Limited.
 Ark Recycling Limited.
 Artemis Medical And Surgical Centre North Shore Limited.
 Ashe Environmental Consultants Limited.
 Ashfield Engineering Limited.
 Asia Food And Beverage New Zealand Limited.

- Asia Pacific Travel Marketing Services Limited.
 Aspirations Apparel Limited.
 Asqew-Reef Limited.
 Aston Media Limited.
 Astute Technology Services Limited.
 Atlantis Technologies Limited.
 Auckland 24 Hours Towing Limited.
 Auckland Building Services Limited.
 Auckland Cruising Club Limited.
 Auckland Developments Limited.
 Auckland Hire Limited.
 Auckland Motorcycle Centre Limited.
 Auckland Waterblasting (1994) Limited.
 Aum Consultants Limited.
 Aura Holdings Limited.
 Austral Asia Consulting Limited.
 Australasian Automotive Advances Limited.
 Australian Gold (NZ) Limited.
 Auto Bac Limited.
 Auto Consultants Limited.
 Axes Limited.
 B & T Prenailers Limited.
 B J Davison Panelbeaters Limited.
 Bardoe Limited.
 Bardslin Enterprises Limited.
 Bartlett Investments Limited.
 Beach Holdings Limited.
 Beach Road Residential Limited.
 Bedshed (NZ) Limited.
 Bees Knees Pharmaceuticals Limited.
 Begg & Butcher Properties Limited.
 Beiwell Trading Co Limited.
 Belvedere Flats Limited.
 Bennetts Auto Panel Repairs Limited.
 Beresford Associates Limited.
 Bianchi Bicycles New Zealand Limited.
 Bishop Group Limited.
 Bitka Management Services Limited.
 Bizziblooms Limited.
 Bma Limited.
 Boat City Limited.
 Bob Tails Limited.
 Bobb Limited.
 Bodmin Properties Limited.
 Boppard Developments Limited.
 Boston Scientific New Zealand Limited.
 Bridgestone Tyres (N.Z.) Limited.
 Bridharl Holdings Limited.
 Brightway Mining Support Services Limited.
 Britest Equipment Company Limited.
 Browns Bay Camera & Hobby Plaza Limited.
 Budget Spouting Limited.
 Burslem Group Limited.
 Bus Nurseries Limited.
 Busby Limited.
 Busy Bee Child Care Centre Limited.
 Buy N Save Limited.
 Cabak Holdings Limited.
 Cambray Developments Limited.
 Camelot Investments Limited.
 Camilla Holdings Limited.
 Canean Holdings Limited.
 Car Audio Shop Limited.
 Cassah Holdings Limited.
 Catchmore Sea Products Limited.
 Catering Supplies Limited.
 Ccf Holdings Limited.
 Cee Vee's Marketing Limited.
 Central City Auto Valet (Auckland) Limited.
 Centrewing Cars Limited.
 Chiew Puah Automation Limited.
 Christopher Hay Construction Company Limited.
 Chrysalis Limited.
 Chuang-Yeh (NZ) Limited.
 Cirrus Holdings Limited.
 Classic Painters Limited.
 Clayton & Frinton Limited.
 Coastal Projects Limited.
 Cobra Imports Limited.
 Cognitum Corporation Limited.
 Collingwood Promotions Limited.
 Colour Pages (Wellington) Limited.
 Comfy Homes Limited.
 Commerce Communications Limited.
 Compleat Design Systems Limited.
 Composite Facilities Solutions Limited.
 Computer Guard Security Systems International Limited.
 Comvision Limited.
 Constant Developments Limited.
 Consulprint Consultants Limited.
 Container Hardware Limited.
 Contour Builders Limited.
 Cook Islands National Line Agency Limited.
 Cool Train Limited.
 Cordless Phones NZ Limited.
 Coronet Asset Management Limited.
 Corporate Calendars Limited.
 Cosmos Business Limited.
 Counties Portable Sawmilling Limited.
 Country Homes Limited.
 Craddock Properties Limited.
 Craven Engineering Limited.
 Crescent Holdings Limited.
 Crocker Property Management South Auckland Limited.
 Cuisine International Limited.
 Custodian 1049 Limited.
 D & B Blanks Limited.
 D.H. Dobbie Plasterers (1992) Limited.
 D.N.J Trading Co. Limited.
 Dae Rentals Limited.
 Datacap Limited.
 Dcm Construction Limited.
 De Haan & Associates Limited.
 Debson Holdings Limited.
 Deer & Game Services N Z Limited.
 Deer Country (NZ) Limited.
 Delfi Data Limited.
 Denco Air Limited.
 Dennis Markson Limited.
 Design Nurseries Limited.
 Dial A Driver N.Z. Limited.
 Dial-A-Light Limited.
 Diamond Developments 2000 Limited.
 Dickson Display Auckland Limited.
 Direct Management Welding Specialties Limited.
 Direct Reader Offers Limited.
 Discounted Investments Limited.
 Disraeli Investments Limited.
 Dobbs & Henwood Joiners (1994) Limited.
 Dome Orbital Structures Limited.
 Downtown Queen Street Backpackers 1993 Limited.
 Dpp Horticulture Limited.
 Drambond Limited.
 Due Pecoroni Limited.
 Dunstan Stockfeed Limited.
 Duval Investments Limited.
 E & A Co Limited.
 E & E Fuzes Investments Limited.
 E Elliott & Co Limited.
 E Print Limited.

- E V T Limited.
Eagle Products (NZ) Limited.
Eagle Publishing Limited.
East Regal 10 Limited.
East Regal 20 Limited.
East Regal 21 Limited.
Ebike Technology Limited.
Ebling Wholesale Limited.
Eco-Vision Developments Limited.
Eftpos Corporation Limited.
Ehbeesea Limited.
Electronic Racing Systems Limited.
Elite Cuisine Services Limited.
Elite Landscapes Co Limited.
Elvia Investments Limited.
Eminent Estates Limited.
Enrich New Zealand Limited.
Enterprise Agencies Limited.
ENZo Design Limited.
Epitome Design Limited.
Equine Pacific 1997 Limited.
Eurocom Limited.
Europhia Ims Limited.
Ever Success International Trading (NZ) Limited.
Everglade Pre-School Learning Centre Limited.
Executive Services (NZ) Limited.
Expert Legal Systems (NZ) Limited.
F W Design Limited.
F.A.M.P. Corporation Limited.
Fair Game Limited.
Federal Properties Limited.
Fill'n Pack Equipment Limited.
Financial Action Limited.
Fine Lingerie Limited.
Fineline Trailers Limited.
First Interiors Limited.
Fish Productions Limited.
Fitness Designs Orewa Limited.
Flag Forward Holdings Limited.
Flat Rock One Limited.
Flexi Golf Vacations (N.Z.) Limited.
Flower Warehouse Group Holdings Limited.
Fore Group Of Companies Limited.
Foreshore Locations Limited.
Foresight Services Limited.
Forged Decor Limited.
Format Limited.
Franklin Draughting Service Limited.
Freight & Distribution NZ Limited.
Fruit Enterprises New Zealand Limited.
Futura Coatings Limited.
Future Benefits And Strategies Limited.
Future Solutions Research And Development Limited.
G G Osborne Consulting Limited.
G H Patel & Sons Limited.
G R Newgoods Limited.
Gablehill Group Limited.
Gainsy Limited.
Garden Style Limited.
Gasbak Marketing Limited.
Gasbak Proprietary Limited.
Gateway Airline Services Limited.
Geared Equities International Limited.
Geoff Young Hotels Limited.
Gilchrist Construction Limited.
Gimis (N.Z.) Enterprise Company Limited.
Gisborne Photo News Art Services Limited.
Glixtone Australasia Limited.
Global Tactics Limited.
Global Trade Connections Limited.
Globalstar New Zealand Limited.
Gold Efx Limited.
Gold Plates Business Centre Limited.
Goodwin & Lethaby Limited.
Gordon Gordon New Technologies Limited.
Granville Holdings Limited.
Graphx Limited.
Grattan Investments Limited.
Great Barrier Structural Services Limited.
Green Pacific Enterprises Limited.
Green Wave 14 Limited.
Green Wave 7 Limited.
Guava Blue Limited.
Gulf Crest Vineyard Limited.
Gulf Harbour Services Limited.
Guy Contractors Limited.
Gyrate Promotions Company Limited.
Gyro Leasing Limited.
H. & H. Slipway Limited.
Haddad Company Limited.
Halla N.Z. Limited.
Halton Investments (NZ) Limited.
Hamble Holdings Limited.
Hamilton Combined Taxis (1997) Limited.
Hamilton Developments Limited.
Han Kook Restaurant Limited.
Happy International Commercial Co Limited.
Harbour Vista Apartments Limited.
Harmonic 7 Limited.
Harrison & Associates Limited.
Hartson Agencies Limited.
Haywards Carpets & Flooring (New Zealand) Limited.
Heart To Heart Cards Limited.
Heat Wheat Products (New Zealand) Pty Limited.
Hemdan House Limited.
Hepple Panel Contracts Limited.
Heritage Printing And Systems Limited.
Hi-Tech Communications Limited.
Hibiscus Medical Services Limited.
Hight Investments Limited.
Hison Industries Limited.
Historic Ships Limited.
Hkp Systems Limited.
Hoko Investments Limited.
Holdwell Group Six Limited.
Holly Developments Limited.
Homefind (1997) Limited.
Horan Integrated Services Limited.
Hospitality Management Limited.
Hotel Publicity International Limited.
Housie Promotions Limited.
Howick Drilling Co Limited.
Hui Yuan International Limited.
Huia Properties Limited.
Huskers Investments Limited.
I.J. Electrical Services Limited.
Ida Holdings Limited.
Imposera Investments Limited.
Inbound Tour Services South Pacific Limited.
Inquest Holdings Limited.
Insight Medix (1994) Limited.
Insight Medix Limited.
Insurance Repair Group Limited.
Interact Industrial Services Limited.
Interactive Media Limited.
Intermak International Limited.
International Symbiotics Limited.
International Television Limited.
Internet Consultants Limited.
Interplay Marketing Limited.
Intrac Tracking Systems Limited.
Investment Marketing Group Limited.

- Iron Lady Limited.
 Irvine Motor Home Rentals Limited.
 Isambard Productions Limited.
 Jacor Limited.
 Jai Maah Laxhmi Enterprises Limited.
 Jainthilal Patel Limited.
 James Credit Real Estate Limited.
 Janegi Enterprises Limited.
 Jas Forwarding (N.Z.) Limited.
 Jel Limited.
 Jetwell Holding Company Limited.
 Jia Sheng Aus-NZ Consultancy Limited.
 Jin Woo Co Limited.
 Jnc Corporation Limited.
 Jones Motor Bodies Limited.
 Julnat Holdings Limited.
 K & H Company Limited.
 K B Homes Limited.
 K N Z Education Centre Limited.
 K.O.D. / Palm Tours Limited.
 Kaitaia Ready Mixed Concrete Limited.
 Kaizen Business Solutions Limited.
 Karangahape Music Limited.
 Kel Marsh Graphic Design Limited.
 Ken Marketing Limited.
 Kennedy Publishing Limited.
 Kimble Enterprises Co Limited.
 King Cheow & Sons Co. Limited.
 King's Way International Marketing Limited.
 Kingston Young Publishing Limited.
 Kinsale Marketing Limited.
 Kirkcaldy Developments Limited.
 Kiwi Lounge Suites And Furniture Limited.
 Kiwi Sheetmetals Limited.
 Kiwi Stationers Limited.
 Kiwi Travel Centre (N.Z.) Limited.
 Kiwi Zulu Seven Limited.
 Ko-Art Development Limited.
 Korean Tofu Limited.
 Kosha Painting And Paperhanging Limited.
 Kotare Consulting Limited.
 Kowhai Development Limited.
 Krish Consultancy Services Limited.
 Kumeu Garden Centre Limited.
 Kun Dat Trading (New Zealand) Limited.
 Kupe Corporate Services Limited.
 Kwong's Pacific NZ Limited.
 L B P Limited.
 Labyrinth International Limited.
 Lakewood Investments Limited.
 Lanlin Chem Limited.
 Lantana Trading Corporation Limited.
 Laranas Investments Limited.
 Laser Action Limited.
 Lauderdale Investments Limited.
 Learning Systems Limited.
 Leithwood Holdings Limited.
 Lelistrolaw Enterprises Limited.
 Lemae Enterprises Limited.
 Lifestyle Plus Limited.
 Lifewish Services Limited.
 Light Fittings Limited.
 Livestock Air Corporation (N.Z.) Limited.
 Location Investments Limited.
 Lontano Properties Limited.
 Love A Duck B.B.Q. Shop Limited.
 Lynkehaven (NZ) Limited.
 Lyren Developments Limited.
 M & T Performance Limited.
 M C F Company Limited.
 M S L Management Selection New Zealand Limited.
 M.G. Atwill Enterprises Limited.
 Maa Limited.
 Macdonald Rentals Limited.
 Madison Consulting (New Zealand) Limited.
 Maiden Systems Limited.
 Maidstone Holdings Limited.
 Mailex NZ Limited.
 Main Management Services Limited.
 Mana Nui NZ Limited.
 Mankind Enterprises Co. Limited.
 Manna Limited.
 Marabou Limited.
 Marach Investments Limited.
 Marble Style Limited.
 Mardon Investments Limited.
 Marfleet Enterprises Limited.
 Marielle Holdings Limited.
 Marina Pharmacy Limited.
 Marlowe Agencies Limited.
 Maromaku Holdings Limited.
 Marshall Bird Immigration Limited.
 Martin Agencies Limited.
 Mason Lawrie & Stainton Solicitors Nominee Company Limited.
 Massey North Service Station Limited.
 Masterframe Limited.
 Matai Management Limited.
 Max Solutions Limited.
 Maxwell Interiors Limited.
 Mcgintys Management Limited.
 Mcleod Consultants Limited.
 Media Circus Limited.
 Mera Corporation Limited.
 Mercury Bay Car Sales Limited.
 Merv Brown Apparel Corporation Limited.
 Metro Fringe Limited.
 Mih Advertising Limited.
 Milburn And Farrierbewley Limited.
 Miniskips Downtown Limited.
 Mission Delivery Service Co., Limited.
 Mission Nominees Limited.
 Mister Spanner Limited.
 Mistley Endeavours Limited.
 Money Plan (1987) Company Limited.
 Monks Communication Consultants Limited.
 Moore Than The Catering Company Limited.
 More Securities Limited.
 Mortgages (N.Z) Limited.
 Muroced Holdings Limited.
 Muroso Construction Services Limited.
 MVP Distribution Limited.
 N & A International Limited.
 N M Studios Limited.
 N.V.L Builders Limited.
 N.Z. Industrial Catering Services Limited.
 Naampeng Company Limited.
 Nanda's Chickenland Limited.
 Naruka Investments Limited.
 Natandola Shelf No. 172A Limited.
 National Aviation Limited.
 Navillus Trading Limited.
 Nebraska Investments Limited.
 Nectar-Ease Distributors Limited.
 Netware Consulting Limited.
 New Age Vending Limited.
 New Loans Limited.
 New Settlers' Business Forum Limited.
 New Sun International Limited.
 New Zealand Aquaculture Federation Limited.
 New Zealand Babylamb Limited.
 New Zealand Education Advisory Services Limited.

- New Zealand Force 10 Trustee Limited.
 New Zealand Panobene Company Limited.
 New Zealand Sport & Adventure Limited.
 New Zealand Winning Company Limited.
 Nga Ngahere O Te Tai Tokerau Limited.
 Ngatiwai Training Limited.
 Night Vision (New Zealand) Limited.
 Nimrod Signs Limited.
 Nomad Project Management Limited.
 Norbert Restaurant Limited.
 North Haul Limited.
 North Regal 11 Limited.
 North Regal 2 Limited.
 North Regal 21 Limited.
 North Shore Business Centre Limited.
 Northern Computers Inc (NZ) Limited.
 Northside Flexo Limited.
 Ntn Publishing Limited.
 Nu Form Plastics Limited.
 Nurse Call Limited.
 Nutrition Direct Limited.
 NZ Transport Exhibitions Limited.
 Ocean Dragon Limited.
 Ocean Plumbing And Gas Fitting Limited.
 Ohai Hotel (1990) Limited.
 Olerex Limited.
 One Tree Hill Plumbing Limited.
 Onehunga Jewellers 1988 Limited.
 Ony Davies Agency Limited.
 Open Flight 15 Limited.
 Open Flight 21 Limited.
 Owhanake Estate Limited.
 Oz & Kiwi Limited.
 Ozone Investments Limited.
 P & R Timber Supplies Limited.
 P S And J A Probett Limited.
 P.E. Michael Limited.
 P.K. Panelbeaters Limited.
 Pacford Corporation Limited.
 Pacific Chiropractic Centres Of New Zealand Limited.
 Pacific Connection Travel Limited.
 Pacific Rim Corp Limited.
 Pacifica Trading Company Limited.
 PacktraNZ (NZ) Limited.
 Painting Projects Limited.
 Pakihi Tours (NZ) Limited.
 Pan Korea Limited.
 Paragon Project Management (N.Z.) Limited.
 Paratu Limited.
 Park View Farms Limited.
 Parnell Records And Tapes Limited.
 Partners In Performance Limited.
 Pauline Cardon Promotions Limited.
 Pauline Lowe Investments Limited.
 Payback Productions Limited.
 PC Net Limited.
 PC Warehouse (NZ) Limited.
 Pengco Limited.
 Perigian 10 Limited.
 Pete The Butyl Man Limited.
 Peter Campbell Limited.
 Peter Vaughan Seminars Limited.
 Petmart Pakuranga Limited.
 Phoenix Finance Limited.
 Pinemeadows Water Company Limited.
 Pipe Technologies Limited.
 Plimmer House Limited.
 Positive Prints & Plates & Company Limited.
 Powell Taxis Limited.
 Precision International Investments Limited.
 Precision Painting (1997) Limited.
 Premier Intertrade NZ Limited.
 Premier Roofing Products N.Z. Limited.
 Prime Photoposter Limited.
 Probert Enterprises Limited.
 Probuild Construction Consultants (NZ) Limited.
 Procon Developments Limited.
 Profile Classic Vehicles Limited.
 Profile Three Limited.
 Programmers Direct Limited.
 Property Investments Four Limited.
 Property Investments Two Limited.
 Property Promotions Limited.
 Provincial Panelbeaters Limited.
 Pt Manderson Contractors Limited.
 Pupuke Service Station Limited.
 Pw Wgtn Nominees Limited.
 Pwimawy Productions Limited.
 Quality Coachlines Limited.
 Quality Product Marketing Limited.
 R & R Tiling Limited.
 R & R Tractors Limited.
 R A Smith Limited.
 R J Leggett Holdings Limited.
 R Power Car Accessories Limited.
 Rainbow Painters Limited.
 Rainbow Trading Limited.
 Rangimotia Holdings Limited.
 Rapata Cooper Resource Limited.
 Ray Blaber & Sons Limited.
 Realise Consulting Limited.
 Realty 4 Visions Limited.
 Red Coats Cleaning Franchise Limited.
 Red Ring Rubbish Limited.
 Regan Construction Limited.
 Regional Holdings Limited.
 Registry Services Limited.
 Repulse Bay Limited.
 Revenir Imports Limited.
 Revision X Computers Limited.
 RG & B Taylor Limited.
 Rhino Automotive Limited.
 Richardson Pratt & Associates Limited.
 Ridley Associates Limited.
 Robanda (N.Z.) Limited.
 Robyn Mulgrew Trading Limited.
 Rock Gully Limited.
 Roller Force Limited.
 Ron Jeffery Limited.
 Roof Rack City Limited.
 Roofing World Limited.
 Rosa Holdings Limited.
 Rose Court Motel Limited.
 Roskill Curtains Limited.
 Rosma Holdings Limited.
 Rossiter Strathmore Syme Limited.
 Rothbury Insurance Brokers Limited.
 Rothschild Properties Limited.
 Rotweiller Investments Limited.
 Rowen Developments Limited.
 Rowley Importing And Property Corporation Limited.
 RSL Construction Limited.
 Runshire Limited.
 Rups Holdings Two Limited.
 Russell Hayward Panel Limited.
 Russian Trade Development Limited.
 RWS Selective Limited.
 S F Robinson Limited.
 S J Hick Limited.
 S.S. Yachts Limited.
 Saga Supplies Limited.
 Sagaram Consulting Limited.

- Saiko Consultants Limited.
Saiph Properties Limited.
Sallach Limited.
Sally International Trading (A & N.Z.) Company Limited.
Samson Forest Investments Limited.
San Sebastian Holdings Limited.
Sandspit Investments Limited.
Satelite Technology Limited.
Savannah Holdings Limited.
Scanlan Investments Limited.
Scarletta Limited.
Science And Trade (New Zealand) Limited.
Sco-Hwa Foods Limited.
Scope Consulting Limited.
SCR (NZ) Limited.
Seafood Garden Limited.
Sew-New Manufacturing Limited.
Sharemarket Software Limited.
Sheperds Calling Limited.
Shoreville Caterers (1988) Limited.
Sidrain Holdings (No. 12) Limited.
Signet Rings (NZ) Limited.
Sinopac International Limited.
Sintai (N.Z.) Limited.
Sky Systems Limited.
Snack Attack (Rotorua) Limited.
So Young Company Limited.
Sojo Group Limited.
Somerdale Poultry Lodge Limited.
South Auckland Prenail And Truss Company Limited.
South Pacific Express (NZ) Limited.
South Pacific Leather Product Co. (NZ) Limited.
South Pacific Tennis Tours Limited.
South Regal 10 Limited.
South Regal 20 Limited.
South Regal 30 Limited.
Sovereign Investment Aust. Limited.
Spanish Tours (New Zealand) Limited.
Spokane Holdings Limited.
Sport Engineering Limited.
Sportspac Corporation Limited.
Sprig Of Thyme Limited.
Standard 728 Limited.
Stanley-Hunt Bulldozing Limited.
Stanley-Hunt Earthmoving Contractors Limited.
Starquest Investments Limited.
Sterling Engineering 1982 Limited.
Stewart Contractors Limited.
Stickman Limited.
Straightline Enterprises Limited.
Strata Nominee Company Limited.
Streamline Aluminium Spouting Limited.
Sunny Corporation (NZ) Limited.
Sunshine Associates Limited.
Super Print Limited.
Supertyre Group Holdings Limited.
Surahi Indian Cuisine Limited.
Sweeney Properties Limited.
Swinson Holdings Limited.
Syzygy Solutions Limited.
T & D Melrose Limited.
Tag Wholesale Cars Limited.
Takapuna Jewellers Limited.
Takashi Motors Limited.
Take 3 Limited.
Talon Bland Limited.
Tangata Records Limited.
Taped Learning Corporation Limited.
Target Marketing (Australasia) Limited.
Tarquin Nominees Limited.
Taruna & Taral's Trading Co Limited.
Tbh Enterprises Limited.
Te Atatu Wholesale Meats Limited.
Te Koha New Zealand Limited.
Telstar Marketing Limited.
Terra Nova Concerts Limited.
The Boxed Beef Company Limited.
The Excellent Event Company Limited.
The Fortune Holdings Limited.
The Global Solutions Consulting Group Limited.
The Golden Four Limited.
The Kiwi New Zealand Trading Company Limited.
The Look (N.Z.) Limited.
The Odd Job Man Limited.
The Original Santa Letter Limited.
The Physios Limited.
The Rain Project Limited.
The Sahara Trust Co Limited.
The Spine Clinic Limited.
The Systems Revolution Limited.
The Underworld Limited.
The Walt Disney Company (New Zealand) Limited.
Tidelinez Limited.
Tiger (NZ) Limited.
Tiger Group International (NZ) Limited.
Tiger International Limited.
Tilt Silver Limited.
Timless International Limited.
Tobin Family Limited.
Together Life Co Limited.
Toledo Securities Limited.
Top Bake (N.Z.) Limited.
Toroa Publishing Limited.
Totem Distributors Limited.
Touchstone Direct Limited.
Trans Ocean Developments Limited.
Tranzs National Legal Services Limited.
Travel Consortium Co Limited.
Travel Solutions New Zealand Limited.
Tri-Biz Dimensions Limited.
Tru Fit Industries Limited.
Trustwood Forests (NZ) Limited.
Twhigg Computer And Management Services Limited.
Ultimate Distributors Limited.
Union Developments Limited.
Unipower Sales Services Limited.
Unison Company Limited.
United Development Limited.
Universal Media Limited.
Uptown Flowers Limited.
Urok Limited.
Vanguard Enterprises Limited.
Venture Exone Limited.
Video Engineering Limited.
Vikings International Klub Limited.
Villa Roofing Limited.
Vistax Holdings Limited.
Visual Systems Limited.
Volbar Restaurants Limited.
Waddon Holdings Limited.
Waiheke Chalet Developments Limited.
Waiheke Landfill Limited.
Waikoukou Valley Promotions Limited.
Waitakere Rangers Limited.
Welcome Bay Hot Pools Limited.
Well-Don Group Limited.
Wellington Accident And Emergency Clinics Limited.
West Regal 19 Limited.
West Regal 29 Limited.
West Regal 9 Limited.
Western Electrical Services Limited.

Western Tarpaulins & Covers Limited.
 Whai-Ora Limited.
 Whanganui Bay Projects Limited.
 Whangarei Earth Improvers Limited.
 Wheels Down Under Waiheke Limited.
 White Disc 16 Limited.
 White Knight Security Limited.
 Whitehall Industries (N.Z.) Limited.
 Whitianga Foodmaster Limited.
 Whitley Holdings Limited.
 Whyte Adder No. 26 Limited.
 Willregal 11 Limited.
 Willregal 2 Limited.
 Wilson Contractors Limited.
 Wind International Co Limited.
 Windsor Resources Corporate Limited.
 Wire Worx Limited.
 Woodill Investments Limited.
 Work & Save Limited.
 Worship Espresso Limited.
 X Factor Finance Limited.
 Xin Qi International Limited.
 Y.K.G. Trade (NZ) Limited.
 Yip's Investment Limited.
 Yun Thai Limited.
 Zennith Publishing Limited.

Contact for Inquiries: The Help Desk, Auckland.
 Telephone No.: (09) 912 7677. Facsimile No.:
 (09) 912 7787.

Postal Address for Written Objections: The Registrar of
 Companies, Private Bag 3090, Hamilton.

NEVILLE HARRIS, Registrar of Companies.

ds6116

Notice of Intention to Remove Companies From the Register

I intend to remove the under-mentioned companies from
 the Register under section 318 of the Companies Act 1993.

I am satisfied that these companies have ceased to carry on
 business and there is no other reason for these companies to
 continue in existence.

Written objections to the company's removal, specifying
 the grounds relied on, can be made under section 321 of
 the Companies Act 1993. These must be delivered to
 the District Registrar of Companies at Hamilton within
 20 working days of publication of this notice.

A J AUTOS LIMITED.
 A S WINTON HOLDINGS LIMITED.
 A. & M. ROGER INVESTMENTS LIMITED.
 A1 CARPET CLEANERS LIMITED.
 AAA TAXIS LIMITED.
 ABLE DRAINAGE WORK AND LABOUR HIRE
 LIMITED.
 ACCORD FINANCIAL SERVICES LIMITED.
 ACTON FRASER AND ASSOCIATES LIMITED.
 ADAM WADE CARRIERS LIMITED.
 ALEXANDER ELECTRICAL LIMITED.
 ALLAN SCOTT LIMITED.
 ALPHERVILLE INTERNATIONAL ENTERPRISES
 LIMITED.
 AMERICAN NEW ZEALAND FUND II LIMITED.
 AMPLIFIER CONSULTANTS LIMITED.
 ANDREW RUSSELL LIMITED.
 ANGEL INVESTMENTS LIMITED.
 ANNABEL M YOUNG LIMITED.
 ANNEX TAXIS LIMITED.
 ASHFORD INFORMATION SERVICES LIMITED.

ASIAN TECHNOLOGY DEVELOPMENTS (NZ)
 LIMITED.
 ASTRO DEVELOPMENTS LIMITED.
 ATKINSON & BLOOMFIELD HOLDINGS
 LIMITED.
 AUTO CRAFT LIMITED.
 BARKSMART NEW ZEALAND LIMITED.
 BARTHOLOMEW PROPERTIES LIMITED.
 BASSEK MANAGED MARKETING LIMITED.
 BEACON ENTERPRISES LIMITED.
 BEN-REA ENTERPRISES LIMITED.
 BERRYS BOOKSHOP LIMITED.
 BIG SAVINGS SHOP LIMITED.
 BOUNTY PROMOTIONS LIMITED.
 BRADCOM CONTRACTING LIMITED.
 BRI-DI ENTERPRISES LIMITED.
 BRYANT CONSTRUCTION GROUP LIMITED.
 BUCKINGHAM ROSS TRUST LIMITED.
 BUENA SECURITIES LIMITED.
 BUSINESS ADVISORY SERVICES LIMITED.
 BUSINESS PLACEMENTS LIMITED.
 CABLEX LIMITED.
 CAFE KHOINOOR LIMITED.
 CALEDONIAN HOLDINGS LIMITED.
 CAMP HI-DE-HI LIMITED.
 CAPITAL AFFAIRS LIMITED.
 CAPRICE CONTRACTORS LIMITED.
 CAPSTONE INVESTMENTS LIMITED.
 CEDEL PRODUCTS N Z LIMITED.
 CENTRAL AUTO COURT LIMITED.
 CHAMCO ENTERPRISES LIMITED.
 CHANTICLEER ENTERPRISES LIMITED.
 CHATELS LIMITED.
 CHEERS INDOOR SPORTS ARENA LIMITED.
 CHEPSTOW INVESTMENTS LIMITED.
 CITY DEVELOPMENTS AND CONSTRUCTION
 LIMITED.
 CLASS ACT LIMITED.
 COLIN & JANET VESTY LIMITED.
 COMPUTER LEARNING CENTRE (AUCKLAND)
 LIMITED.
 CONTAINERISED STORAGE LIMITED.
 COPPER COMPANY LIMITED.
 COTTER ENTERPRISES LIMITED.
 CRANFIELDS LIMITED.
 CRITCHLEY & HAY ABBEY ROAD LIMITED.
 CROFTON MOTORS LIMITED.
 CROSS KEYS HOLDINGS LIMITED.
 D M SHEPHERD & SONS LIMITED.
 D.A. RICHARDS & ASSOCIATES LIMITED.
 DELTA SECURITIES LIMITED.
 DELTAK TRAINING CORPORATION LIMITED.
 DENTICE DECORATING LIMITED.
 DISCOVERY IMPORTS LIMITED.
 DON ABERNETHY 1981 LIMITED.
 DON OLIVER FITNESS CITY PARAPARAUMU
 LIMITED.
 DOROTHY PATISSERIE (ESTABLISHED 1930)
 LIMITED.
 DREAM TEAM SPORTS LIMITED.
 DRK MARKETING LIMITED.
 DROF NOMINEES LIMITED.
 DYNACO ELECTRICAL LIMITED.
 EADE LIMITED.
 EASTBOURNE TAVERN LIMITED.
 EASTRADE PROPERTY SERVICES LIMITED.
 ECOSAVE LIMITED.
 ELECTRO CHILL LIMITED.
 ENTERPRISE SYSTEMS CONSULTANCY
 LIMITED.
 ENTERTAINING FINANCIAL SERVICES LIMITED.

EPAL (N.Z.) HOLDINGS LIMITED.
 EQUICARE PRODUCTS LIMITED.
 ERGODESIGN ASSOCIATES LIMITED.
 ERSKINE INTERNATIONAL LIMITED.
 ESPRESSAHOLIC LIMITED.
 ESSENTIAL ART LIMITED.
 EUROFORDABLE CARS (NZ) LIMITED.
 F USMAR LIMITED.
 FILLETS LIMITED.
 FIRST NATIONAL FINANCE CORPORATION LIMITED.
 FIRST NATIONAL LIMITED.
 FLETCHER QUAYLE & BURNS LIMITED.
 FOOTLOOSE PROPERTIES LIMITED.
 FOXLEY ENGINEERING LIMITED.
 FREEDOM MORTGAGE SERVICES LIMITED.
 FRESHPOP (NZ) LIMITED.
 FULFILLMENT LIMITED.
 FUTURE CARD INVESTMENTS THIRTY TWO LIMITED.
 GILMOND LIMITED.
 GOLD PLATEAU LIMITED.
 GREEN SILO HOLDINGS LIMITED.
 GROUP INSURANCE SPECIALISTS LIMITED.
 GT ENTERPRISES LIMITED.
 H G MANUFACTURING LIMITED.
 H P YARRELL LIMITED.
 HANNAM INVESTMENTS LIMITED.
 HARBOUR CAPITAL WINE AND FOOD FESTIVAL LIMITED.
 HEATHRAE PROJECTS LIMITED.
 HERBAL INTERNATIONAL LIMITED.
 HI TECH COATING SYSTEMS LIMITED.
 HILL ASSURANCE BROKERS LIMITED.
 HO INVESTMENTS NO. 106 LIMITED.
 HO INVESTMENTS NO. 116 LIMITED.
 HO INVESTMENTS NO. 14 LIMITED.
 HO INVESTMENTS NO. 30 LIMITED.
 HO INVESTMENTS NO. 36 LIMITED.
 HO INVESTMENTS NO. 43 LIMITED.
 HO INVESTMENTS NO. 51 LIMITED.
 HO INVESTMENTS NO. 67 LIMITED.
 HO INVESTMENTS NO. 74 LIMITED.
 HO INVESTMENTS NO. 82 LIMITED.
 HO INVESTMENTS NO. 87 LIMITED.
 HO INVESTMENTS NO. 92 LIMITED.
 HO INVESTMENTS NO. 97 LIMITED.
 HOT TOMATO LIMITED.
 HOUSEHOLD FINANCE LIMITED.
 INTERIORS BY MOORE LIMITED.
 INTERIORZ LIMITED.
 ISLAND BAY HOLDINGS LIMITED.
 IWI CONNECTIONS LIMITED.
 J. AND C. DYBALL LIMITED.
 JACK IN THE BOX LIMITED.
 JNB INTERNATIONAL LIMITED.
 JOHN FOTHERGILL LIMITED.
 JOINTSEALING CONTRACTORS LIMITED.
 JON LOVE FORKLIFTS LIMITED.
 KAHUNUI FARM LIMITED.
 KAPITAL FINANCIAL SERVICES LIMITED.
 KAPITI ADVISORY SERVICES LIMITED.
 KAPITI SPORTING LIFE LIMITED.
 KEA DEVELOPMENTS LIMITED.
 KEN WEST CONSULTING LIMITED.
 KENNEDY PROPERTY LIMITED.
 KERRY WADDELL TENNIS ENTERPRISES LIMITED.
 KERRY'S NURSERY LIMITED.
 KIA ORA KAI LIMITED.
 KILADA HOLDINGS LIMITED.
 KILTANON ORCHARD LIMITED.
 KNAPPO INVESTMENTS LIMITED.
 KOWHAI CREAM LIQUEUR LIMITED.
 L AND S CONTRACTING LIMITED.
 L V MARTIN WHOLESALERS LIMITED.
 LAKEMAN HOLDINGS LIMITED.
 LANDMARK SERVICE STATION 1982 LIMITED.
 LAVENDER BLUE LIMITED.
 LIFESTYLE SYSTEM LIMITED.
 LISBON LIONS LIMITED.
 LITE 2000 LIMITED.
 LORD NELSON TAVERN LIMITED.
 LYCETT HALL CONSULTING LIMITED.
 MACLAND FARMS LIMITED.
 MAHOE INDUSTRIES (1985) LIMITED.
 MAHONY REAL ESTATE LIMITED.
 MAHURI 18 COMPANY LIMITED.
 MANARATOR INVESTMENTS LIMITED.
 MANHAAS INDUSTRIES LIMITED.
 MANHAAS LIMITED.
 MANOR HOUSE PRESS LIMITED.
 MARLBOROUGH VENTURES LIMITED.
 MATES HAIR FASHIONS LIMITED.
 MATURE EMPLOYMENT SERVICE WELLINGTON LIMITED.
 MCMAHON ENTERPRISES LIMITED.
 MEICHTRY INVESTMENTS LIMITED.
 MENTOR SERVICES LIMITED.
 MERIC DUNSTAN HOLDINGS LIMITED.
 MICRON INTERNATIONAL LIMITED.
 MICROSTAK FURNITURE LIMITED.
 MIDKNIGHT CHARTERS (93) LIMITED.
 MILLAR MASONRY LIMITED.
 MINZ SERVICES LIMITED.
 MONTE CARLO INVESTMENTS LIMITED.
 MOODIE AGRICULTURAL CONTRACTORS LIMITED.
 MOSCOW ICE SHOW MANAGEMENT CO. LIMITED.
 MR LIFTER LIMITED.
 MULTI STORE DIRECT LIMITED.
 N B J LIMITED.
 N.Z. SUMMERFRUIT EXPORT COUNCIL LIMITED.
 N.Z. UNDERWATER WORLD ENGINEERING AND DEVELOPMENT CO LIMITED.
 NATIONAL ASSETS CONTROL LIMITED.
 NEON RAIN LIMITED.
 NETWORK REALTY NEW ZEALAND LIMITED.
 NEW LIFE KITCHENS & STAIRS LIMITED.
 NEW ZEALAND INSTITUTE OF SPORTS LIMITED.
 NEW ZEALAND LANDSCAPE CONTRACTING CO LIMITED.
 NINA CONTI LIMITED.
 ON AIR INTERNATIONAL LIMITED.
 ONTIME INFORMATION SYSTEMS LIMITED.
 OPTIMUM CINEMA SYSTEMS (AUSTRALASIA) LIMITED.
 ORIENT ASSET MANAGEMENT LIMITED.
 OUTSIDE THE BOX LIMITED.
 P.J. COOPER BUILDERS LIMITED.
 PACIFIC CABLE & NETWORK CONSTRUCTION LIMITED.
 PACIFIC ISLAND (N.Z.) CONSULTANTS LIMITED.
 PAF CORPORATE SERVICES LIMITED.
 PAGE DATA PRODUCTS LIMITED.
 PALMERSTON NORTH VEHICLE FINANCE LIMITED.
 PARBHU ENTERPRISES LIMITED.
 PEGASUS CHARTER LIMITED.

PER MARE PER TERRAS LIMITED.
 PERIDOT INVESTMENTS LIMITED.
 PERRY SECURITIES LIMITED.
 PERSONAL COMPUTER SOLUTIONS LIMITED.
 PINEDALE ENTERPRISES LIMITED.
 PIONEER PAINTING CO LIMITED.
 PN SERVICES LIMITED.
 POCKET SAVERS LIMITED.
 PRECISION CUTTING FORMES (1984) LIMITED.
 PRODUCER INVESTMENTS LIMITED.
 QUADGROUP (NZ) LIMITED.
 RACK TECHNOLOGIES LIMITED.
 REDWOOD SECURITY SYSTEMS (WGTV)
 LIMITED.
 REEL MANAGEMENT SERVICES LIMITED.
 ROMNEY (NO.15) LIMITED.
 RON KNIGHT LIMITED.
 RON MANSFIELD LIMITED.
 RUBY INVESTMENTS LIMITED.
 SAFETY FLOORS (WGTV) LIMITED.
 SAFTEY TECHNOLOGY LIMITED.
 SAMBA CORPORATION LIMITED.
 SATAY TIME LIMITED.
 SCALA TECHNICAL SERVICES LIMITED.
 SCOTT CONSULTING/CONTRACTING LIMITED.
 SCRIP INVESTMENTS LIMITED.
 SHANKLY HOLDINGS LIMITED.
 SHORE BIRD RESTAURANT LIMITED.
 SILVER INVESTMENTS LIMITED.
 SILVERSTONE EUROPEAN (NZ) LIMITED.
 SIMPLE SOLUTIONS CONSULTING LIMITED.
 SMARTCARD NZ LIMITED.
 STRAND PROPERTY LIMITED.
 SUPERLEAGUE LIMITED.
 SURAPON TRADING LIMITED.
 SURVIVE (NEW ZEALAND) LIMITED.
 SYSTEM-AIR LIMITED.
 T J KILLALEA SOLICITORS NOMINEE
 COMPANY LIMITED.
 T K S PROJECTS LIMITED.
 T.K.S.(NZ) LIMITED.
 TAMA PROPERTIES LIMITED.
 TE MAKARINI ASSOCIATES LIMITED.
 TE-AWARERE ENTERPRISES LIMITED.
 TE. T. WHITE CONSULTANCY LIMITED.
 TECHNOLOGY RESOURCE MANAGEMENT
 LIMITED.
 THE FURNITURE REMOVAL COMPANY
 LIMITED.
 THE LOST FORESTS NEW ZEALAND LIMITED.
 THOMAS CONFECTIONERY LIMITED.
 TIVOLI DEVELOPMENTS LIMITED.
 TORRO HOLDINGS LIMITED.
 TOURISM INTERNATIONAL SERVICES LIMITED.
 TRAVEL INCORPORATED LIMITED.
 TRITON TECHNOLOGIES LIMITED.
 TROPHIES AWARDS & REWARDS LIMITED.
 TURKEY HOLDINGS LIMITED.
 ULTIMATE DEVELOPMENTS LIMITED.
 UNAWA INVESTMENTS LIMITED.
 UNITY MUTUAL FINANCIAL SERVICES
 LIMITED.
 VALLEY PRESS KNIVES LIMITED.
 WAIRARAPA VEHICLE FINANCE LIMITED.
 WAKEFIELD INVESTMENTS LIMITED.
 WANGANUI FUNERAL HOME (& DIRECTORS)
 LIMITED.
 WATERLOO PHARMACY LIMITED.
 WELLINGTON PROSPERITY TRADING LIMITED.
 WILLIAMS & DOYLE CABINET MAKERS
 LIMITED.

WILLOWDENE REST-HOME LIMITED.
 WOODWARD DAVEY LIMITED.
 ZENITH MARKETING LIMITED.

Postal Address for Written Objections: The Registrar of Companies, Private Bag 3090, Hamilton.

NEVILLE HARRIS, Registrar of Companies.

ds6126

Notice of Intention to Remove Companies From the Register

Pursuant to Section 295 (2) of the Companies Act 1955

Notice is hereby given that, pursuant to section 293 (1) (e) of the Companies Act 1955, the Registrar will be removing the following companies from the Register on the grounds that the liquidator has completed his duties.

The liquidator has delivered the documents referred to in section 231 of the Companies Act 1955 to the Registrar. Any objection to removal under section 296 of the Companies Act 1955, must be delivered to the District Registrar of Companies, Private Bag 92-061, Wellesley Street, Auckland, within 20 working days of the date of this notice.

The registered office of the companies is situated at the office of the Official Assignee, Sixth Floor, District Court Building, 3 Kingston Street, Auckland.

Seal-it Auckland Limited.
 Promo Groups Co Limited.
 Nationwide Sales Limited.
 Hospitality Plus Limited.
 Chase Corporation Limited.
 Dale & Fyfe Investments Limited.
 B & H Machinery Limited.
 Northern Informer Limited.
 Topo Gigio Restaurants Limited.
 Mech Tech NZ Limited.
 International Jobsearch (NZ) Limited.
 Konikoko Holdings Limited.
 Club Warehams (Pakuranga) Limited.
 ALH (1994) Limited.
 Photo King Network Limited.
 John Gibbons Electrical Wholesale Limited.
 Loch Carron Farms Limited.
 Trans-Waste Limited.
 Number One Shipping Limited.
 Heipac Limited.
 Youngs Transport Limited.
 The Differenz Company Limited.
 Tax Limited.
 Creative Intelligence Associates Limited.
 Allied Appliances (1972) Limited.
 Ready Flooring Limited.
 Sams Supermarket Limited.
 Abdul's Food Market Limited.
 Double RR Country Lodge Limited.
 Troy Engineering Limited.
 Nicadam Holdings Limited.
 Fair Enterprises (NZ) Limited.
 Potato Factory Limited.
 Vision Arts Limited.
 Jervois One Holdings Limited.
 West End Investments Limited.

OFFICIAL ASSIGNEE/LIQUIDATOR.

ds5987

South Pacific Cargo Limited**Notice of Intention to Apply for Removal of Company From the Register**

Notice is hereby given that I, the undersigned applicant, propose to apply to the Registrar of Companies at Auckland, pursuant to section 318 (1) (d) (i) of the Companies Act 1993, for the removal of South Pacific Cargo Limited, whose registered office is situated at 11-13 Falcon Street, Parnell, Auckland, from the New Zealand Register on the grounds that the company has ceased to carry on business, has discharged in full its liabilities to all its known creditors and has distributed its surplus assets in accordance with the Companies Act 1993.

Unless written objection to such removal, pursuant to section 321 of the Act, is sent or delivered to the Registrar at Auckland by the 24th day of September 1998 (being a date not less than 20 working days after the date of this notice), the Registrar may remove the company from the Register.

Dated at Auckland this 27th day of August 1998.

JEFFREY ALAN SEDGWICK.

ds5990

South Pacific Group Services Limited (formerly ICON Aviation Limited)**Notice of Intention to Apply for Removal of Company From the Register**

Notice is hereby given that I, the undersigned applicant, propose to apply to the Registrar of Companies at Auckland, pursuant to section 318 (1) (d) (i) of the Companies Act 1993, for the removal of South Pacific Group Services Limited (formerly ICON Aviation Limited), whose registered office is situated at Level Five, Kensington Swan Building, 22 Fanshawe Street, Auckland, from the New Zealand Register on the grounds that the company has ceased to carry on business, has discharged in full its liabilities to all its known creditors and has distributed its surplus assets in accordance with the Companies Act 1993.

Unless written objection to such removal, pursuant to section 321 of the Act, is sent or delivered to the Registrar at Auckland by the 24th day of September 1998 (being a date not less than 20 working days after the date of this notice), the Registrar may remove the company from the Register.

Dated at Auckland this 27th day of August 1998.

JEFFREY ALAN SEDGWICK.

ds5991

Sancom Investments Limited (in liquidation)**Notice of Intention to Remove Company From the Register**

The liquidation of the above-named company, whose registered office is care of Ken Howard & Associates, 188 Kapiti Road, Paraparaumu, has now been completed.

The liquidator's final report and accounts, pursuant to section 257 of the Companies Act 1993 ("the Act"), have been sent to the Registrar, together with a request that the company be removed from the Register.

Any objections to the removal, pursuant to section 321 of the Act, must be delivered to the Registrar by the 18th day of September 1998.

Dated this 17th day of August 1998.

K. A. HOWARD, Liquidator.

ds5973

Long Line Shoes NZ Limited**Notice of Application for Removal of Company From the Register**

Long Line Shoes NZ Limited, a duly incorporated company having its registered office at 23-29 Albert Street, Auckland, hereby gives notice of an application to the Registrar of Companies for removal from the Register, pursuant to section 318 (1) (d) of the Companies Act 1993, on the grounds that it has ceased to carry on business, has fully discharged its liabilities to all its known creditors and has distributed its surplus assets in accordance with the Companies Act 1993.

The date by which an objection to the removal, under section 321 of the Companies Act 1993, must be delivered to the Registrar is the 15th day of September 1998.

Dated this 13th day of August 1998.

C. R. MACLACHLAN, Director.

ds5974

Haitari Holdings Limited**Notice of Intention to Apply for Removal of the Above Company From the Register**

Notice is hereby given that we, the undersigned applicants, propose to apply to the Registrar of Companies at Auckland, pursuant to section 318 (1) (d) of the Companies Act 1993, for the removal of Haitari Holdings Limited, whose registered office is situated at 3 Hopetown Street, Auckland, from the New Zealand Register on the grounds that the company has ceased to carry on business, has discharged in full its liabilities to all its known creditors and has distributed its surplus assets in accordance with its constitution and the Companies Act 1993.

Unless written objection to such removal, pursuant to section 321 of the Act, is sent or delivered to the Registrar at Auckland by the 28th day of September 1998 (being a date not less than 20 working days after the date of this notice), the Registrar may remove the company from the Register.

Dated at Auckland this 17th day of August 1998.

Signed for and on behalf of Haitari Holdings Limited, by:

HERBERT WILLIAM MOOR, Director.

ds5975

The Baby Boutique Limited (in liquidation)**Notice of Intention to Remove Company From the Register**

Pursuant to Section 320 (2) of the Companies Act 1993

Notice is hereby given that, pursuant to section 318 (1) (e) of the Companies Act 1993 the Registrar will be removing the above company from the Register on the grounds that the liquidator has completed his duties.

The liquidator has delivered the documents referred to in section 257 of the Companies Act 1993, to the Registrar.

Any objection to removal, under section 321 of the Companies Act 1993, must be delivered to the Registrar by the 3rd day of August 1998.

M. N. FROST, Joint Liquidator.

The Registered Office of the Company is Situated at the

Offices of: Deloitte Touche Tohmatsu, 481 Moray Place,
Dunedin.

ds5976

Kered Limited

Notice of Intention to Remove Company From the Register

Address of Registered Office: 17 The Concourse,
Henderson, Auckland.

Notice is given that it intends to apply, pursuant to section 318 (1) (d) of the Companies Act 1993, to be removed from the Register of Companies on the grounds that it has ceased to carry on business, has discharged in full its liabilities to all its known creditors and has distributed its surplus assets in accordance with the Companies Act 1993.

Any objection to the removal must be delivered to the Registrar of Companies no later than 28 days after the date of this notice.

HARTS, Accountants to the Company.

ds5977

W B Pehi Consultant Limited HN. 456476

Notice of Intention to Remove Company From the Register

Notice is hereby given that I, the undersigned applicant, propose to apply to the Registrar of Companies at Hamilton, pursuant to section 318 (1) (d) (i) of the Companies Act 1993, for the removal of W B Pehi Consultant Limited, whose registered office is situated at 14 Ruapehu Street, Taupo, from the New Zealand Register on the grounds that the company has ceased to carry on the business, has discharged in full its liabilities to all its known creditors and has distributed its surplus assets in accordance with its constitution and the Companies Act 1993.

Unless written objections to such removal, pursuant to section 321 of the Act, is sent or delivered to the Registrar at Hamilton by the 18th day of September 1998 (being a date not less than 20 working days after the date of this notice), the Registrar may remove the company from the Register.

Dated at Taupo this 17th day of August 1998.

A. M. CLARK.

ds5978

River Valley Souvenirs Limited HN. 194900

Notice of Intention to Remove Company From the Register

Pursuant to Section 318 (1) (d) of the Companies Act 1993

Notice is hereby given that, pursuant to section 318 (1) (d) of the Companies Act 1993, the directors have resolved to make application to the Registrar that the company be removed from the Register on the grounds that the company has no surplus assets after paying its debts in full or in part, and no creditor has applied to the Court under section 241 of the Companies Act 1993, for an order putting the company into liquidation.

Any objection to removal, under section 318 (1) (d) of the Companies Act 1993, must be delivered to the District Registrar of Companies, Private Bag 3090, Hamilton, within 20 working days of the date of this notice.

The Registered Office of the Company is Situated at the Office of: Peter Reilly and Peter Stewart, First Floor, Vickery House, 113 Alexandra Street, Hamilton.

Dated this 8th day of August 1998.

A. H. OTTON, Director.

ds5979

M P De Gouw Limited

Notice of Intention to Request Removal of the Company From the Register

Pursuant to Section 318 (1) (d) of the Companies Act 1993

I, Hubert G. T. Kraak, hereby give notice that I intend to apply to the District Registrar of Companies at Christchurch, for the removal of the above-named company, having its registered office at 37 Edward Street (P.O. Box 79), Lincoln 8152, on the grounds specified under section 318 (2) (a) or section 318 (2) (b) of the Companies Act 1993.

Unless written objections are lodged with the Registrar within 20 working days of the date of this notice, the company will be removed from the Register.

Dated this 18th day of August 1998.

HUBERT G. T. KRAAK, Authorised Person.

ds5980

Gretener Farms Limited

Notice of Intention to Apply for Removal of the Above Company From the Register

Notice is hereby given that we, the undersigned applicants, propose to apply to the Registrar of Companies at Napier, pursuant to section 318 (1) (d) (i) of the Companies Act 1993, for the removal of Gretener Farms Limited, whose registered office is situated at the offices of Stretton & Co, Towngate Building, 44 Heu Heu Street, Taupo, from the New Zealand Register on the grounds that the company has ceased to carry on business, has discharged in full its liabilities to all known creditors and has distributed its surplus assets in accordance with its constitution and the Companies Act 1993.

Unless written objection to such removal, pursuant to section 321 of the Act, is sent or delivered to the Registrar at Napier by the 22nd day of September 1998 (being a date not less than 20 working days after the date of this notice), the Registrar may remove the company from the Register.

Dated at Rerewhakaaitu this 13th day of August 1998.

PETER GREENER.

SUSAN MARLIES GREENER.

STEVEN JAMES BIGNELL.

ds6018

The Caring Card Company (International) Limited

Notice of Intention to Apply for Removal of the Above Company From the Register

Notice is hereby given that we, the undersigned applicants, propose to apply to the Registrar of Companies at Auckland, pursuant to section 318 (1) (d) of the Companies Act 1993, for the removal of The Caring Card Company (International) Limited, whose registered office is situated at the offices of Bowden, Impey & Sage, Parnell House, 470 Parnell Road, Auckland, from the Register upon the grounds that the company has ceased to carry on business, has discharged in full its liabilities to all its known creditors and has distributed its surplus assets in accordance with its constitution and the Companies Act 1993.

Unless written objection to such removal, pursuant to

section 296 of the Act, is sent or delivered to the Registrar at Auckland by the 25th day of September 1998 (being a date not less than 20 working days after the date of this notice), the Registrar may remove the company from the Register.

Dated at Auckland this 17th day of August 1998.

Signed for and on behalf of The Caring Card Company (International) Limited by:

MARTIN LESLIE LEAKE, Director.

ds6019

Leafstock Limited

Notice of Intention to Apply for Removal of the Above Company From the Register

Notice is hereby given that I, the undersigned applicant, propose to apply to the Registrar of Companies at Auckland, pursuant to section 318 (1) (d) (i) of the Companies Act 1993, for the removal of Leafstock Limited, whose registered office is situated at 96 Opanuku Road, Henderson, Auckland, from the New Zealand Register on the grounds that the company has ceased to carry on business, has discharged in full its liabilities to all its known creditors and has distributed its surplus assets in accordance with its constitution and the Companies Act 1993.

Unless written objection to such removal, pursuant to section 321 of the Act, is sent or delivered to the Registrar at Auckland by the 30th day of September 1998 (being a date not less than 20 working days after the date of this notice), the Registrar may remove the company from the Register.

Dated this 20th day of August 1998.

MICHAEL GORDON FOSTER, Director.

ds6031

Kowai Bush Enterprises Limited (in liquidation)

Public Notice of Intention to Apply for Removal of Company From the Register

Public notice is given that pursuant to section 318 (1) (e) of the Companies Act 1993, the Registrar of Companies must remove Kowai Bush Enterprises Limited (in liquidation), whose registered office is situated at 575 Colombo Street, Christchurch, from the New Zealand Register on the grounds that the documents referred to in section 257 (1) (a) of the Companies Act 1993, have been sent or delivered to the Registrar of Companies, thereby completing the liquidation, pursuant to section 249 of the Act.

Unless, pursuant to section 321 of the Act, written objection to the removal is delivered to the Registrar by the 30th day of September 1998 (being a date not less than 20 working days after the date of this notice), the Registrar is obliged to remove the company from the Register.

Dated at Christchurch this 21st day of August 1998.

NEIL S. FRANCE, Liquidator.

ds6032

Balcairn Farm Limited

Notice of Intention to Request Removal of a Company From the Register

Pursuant to Section 318 (1) (d) of the Companies Act 1993

I, Doreen Betty Roulston, hereby give notice that I intend to apply to the District Registrar of Companies at Dunedin

for the removal of the above-named company, having its registered office at 20 James Street, Balclutha, on the grounds specified under section 318 (2) (a) or section 318 (2) of the Companies Act 1993.

Unless written objections are lodged with the Registrar within 28 days of the date of this notice, the company will be removed from the Register.

Dated this 27th day of August 1998.

DOREEN BETTY ROULSTON, Company Director.

ds6064

Taihape Carriers Limited

Notice of Intention to Apply for Removal of the Company From the Register

Pursuant to Section 320 of the Companies Act 1993

Notice is hereby given that William Toka King, a shareholder of Taihape Carriers Limited ("the company"), proposes to apply to the Registrar of Companies at Auckland, pursuant to section 318 (1) (d) of the Companies Act 1993 ("the Act") for the removal from the Register of Companies.

The grounds on which William Toka King intends to base his application are that the company:

- (a) Has ceased to carry on business;
- (b) Has discharged in full its liabilities to all its known creditors; and
- (c) Has distributed its surplus assets in accordance with its constitution and the Act.

Unless written objection to the company's removal, pursuant to section 321 of the Act, is sent or delivered to the Registrar at Auckland by the 30th day of September 1998 (being a date not less than 20 working days after the date of this notice), the Registrar may remove the company from the Register.

Dated at Taihape this 21st day of August 1998.

W. T. KING, Liquidator.

ds6066

Bruce Penny Limited

Notice of Intention to Apply for Removal of the Above Company From the Register

Notice is hereby given that we, the undersigned applicants, propose to apply to the Registrar of Companies at Christchurch, pursuant to section 318 (1) (d) (i) of the Companies Act 1993, for the removal of Bruce Penny Limited, whose registered office is situated at Floor Eleven, 155 Worcester Street, Christchurch, from the New Zealand Register on the grounds that the company has ceased to carry on business, has discharged in full its liabilities to all its known creditors and has distributed its surplus assets in accordance with its constitution and the Companies Act 1993.

Unless written objection to such removal, pursuant to section 321 of the Act, is sent or delivered to the Registrar at Christchurch by the 24th day of September 1998 (being a date not less than 20 working days after the date of this notice), the Registrar may remove the company from the Register.

Dated this 27th day of August 1998.

BULLOCK TAYLOR & SHELDON.

ds6067

Tempo Services Limited (in liquidation)**Notice of Intention to Remove Company From the Register***Pursuant to Section 295 of the Companies Act 1955*

We, Richard Dale Agnew and Anthony George Lewis, liquidators of the above company, whose registered office is situated at the offices of PricewaterhouseCoopers, Level Twenty-nine, Coopers & Lybrand Tower, 23-29 Albert Street, Auckland, hereby give notice that, pursuant to section 293 (e) of the Companies Act 1955, and having filed with the Registrar our final reports on the liquidation, it is intended to remove the company from the New Zealand Register.

Any objection to the removal, pursuant to section 296 of the Companies Act 1993, must be delivered to the Registrar no later than 28 days after the date of this notice.

Dated this 21st day of August 1998.

R. D. AGNEW, Liquidator.

ds6069

Brendan McConnell Solicitors Nominee Company Limited**Notice of Intention to Remove Company From the New Zealand Register**

Take notice that it is intended to remove Brendan McConnell Solicitors Nominee Company Limited, whose registered office is at 834 Colombo Street, Christchurch ("the company"), from the New Zealand Register under section 318 (1) (d) of the Companies Act 1993, on the grounds that the company has ceased to carry on business, has discharged in full its liabilities to all its known creditors and has distributed its surplus assets in accordance with its constitution and the Companies Act 1993.

Any objections, under section 321 of the Companies Act 1993, to the removal, must be delivered to the Registrar of Companies, Private Bag 5901, Lambton Quay, Wellington, by the 25th day of September 1998.

Dated this 24th day of August 1998.

B. R. McCONNELL, Director.

ds6132

Fluid Transport Services Limited WN. 636535**Notice of Intention to Apply for Removal of the Company From the Register***Pursuant to Section 320 of the Companies Act 1993*

Notice is hereby given that Anthony Phillip Galbraith of Fluid Transport Services Limited ("the company"), the registered office of which is at 128 Rostrevor Street, Hamilton, proposes to apply to the Registrar of Companies at Wellington, pursuant to section 318 (1) (d) of the Companies Act 1993 ("the Act") for the removal from the Register of Companies.

The grounds on which Anthony Phillip Galbraith intends to base his application are that the company:

- (a) Has ceased to carry on business;
- (b) Has discharged in full its liabilities to all its known creditors; and
- (c) Has distributed its surplus assets in accordance with its constitution and the Act.

Unless written objection to the company's removal, pursuant to section 321 of the Act, is sent or delivered to the Registrar at Wellington by the 23rd day of September 1998 (being a date not less than 20 working days after the date of this notice), the Registrar may remove the company from the Register.

ROBERT ANDREW JANE, Chartered Accountant.

ds6133

Auto Infoline Limited**Notice of Intention to Remove Company From the Register***Pursuant to Section 318 (1) (d) of the Companies Act 1993 (the Act)*

Address of Registered Office: 5 Armadale Road, Remuera, Auckland.

Grounds for Removal: The company has never traded and will not be trading in the future. It has no liabilities nor assets whatsoever.

Date for Objection: Any objection to the removal of this company, under section 321 of the Act, must be delivered to the Registrar no later than 28 working days after the date of this notice.

CORAL WONG, Director.

ds6143

CESSATION OF BUSINESS IN NEW ZEALAND**Aroma Science Pty Limited****Notice of Intention to Cease to Carry on Business in New Zealand***Pursuant to Section 341 of the Companies Act 1993*

Notice is hereby given that Aroma Science Pty Limited will cease to carry on business in New Zealand on the 1st day of December 1998 and, pursuant to section 341 (2) (a) of the Companies Act 1993, will be removed from the Overseas Register.

ROBERT WONG, of Burns McCurrach.

cb5994

Prandf Pty Limited**Public Notice of Intention to Apply for Removal of the Company From the New Zealand Register**

Notice is hereby given that Prandf Pty Limited, an Australian company registered under Part XVIII of the Companies Act 1993, is to apply to the Registrar of Companies to be removed from the New Zealand Register on the grounds that it has ceased to carry on business in New Zealand.

Dated this 26th day of August 1998.

PETER TAYLOR.

cb6054

OTHER**Notice of Intention to Restore Companies to the Register****The Companies Act 1993**

Take notice that the Registrar of Companies at Hamilton proposes to restore the following companies to the Register of Companies:

Baker Bros Service Stn Limited HN. 191617. *Applicant:* Mr and Mrs A. F. Baker, 22 Wychwood Crescent, Rotorua.

Hiko Tours Limited HN. 828269. *Applicant:* Paul Haitana, Pipiriki, R.D. 6, Whanganui.

The Registrar proposes to act under section 328 (1) (a) of the Companies Act 1993, on the grounds that the companies were carrying on business or other reasons existed for the companies to continue in business at the time that they were removed from the register.

Any person who objects to the restoration of any of these companies to the register must deliver notice of that objection in writing to the District Registrar at Hamilton within 20 working days from the date of this notice.

Dated at Hamilton this 27th day of August 1998.

NEVILLE HARRIS, Registrar of Companies.

The address for delivery of any notice is the Registrar of Companies, First Floor, ASB Building, 500 Victoria Street, Hamilton or by post to Private Bag 3090, Hamilton. *Contact Officer:* K. Whitten.

ot6022

Notice of Intention to Restore to the Register**Companies Act 1993**

Take notice that the Registrar of Companies at Auckland proposes to restore the following companies to the Register of Companies.

Debenture Securities Limited AK. 679505. *Applicant:* N. W. Aitken, P.O. Box 33-448, Takapuna.

Geoffrey Dainty Limited AK. 402627. *Applicant:* Geoffrey Dainty, P.O. Box 47-585, Pongsonby.

Film Facilities Limited AK. 426950. *Applicant:* Robert H. Moir, 83 Ngataranga Road, Devonport.

Zarazel Trading Limited AK. 830589. *Applicant:* Abdul Hamid, 569A Richardson Road, Mount Roskill.

Jorson Holdings Limited AK. 593943. *Applicant:* A. Hutchison, P.O. Box 8905, Symonds Street.

Scandinavian Enterprises Limited AK. 834772. *Applicant:* Susanna Palomaki, P.O. Box 11-349, Ellerslie.

Straight Line Communications Limited AK. 864832. *Applicant:* Craig, P.O. Box 37-779, Parnell.

Mold Technology Limited AK. 113225. *Applicant:* R. B. Guise, P.O. Box 21-015, Henderson.

Future Build Limited AK. 702941. *Applicant:* Ian Pennial, 45 Rewi Street, Torbay.

Community Security Limited AK. 810772. *Applicant:* Sean P. McLaughlan, P.O. Box 37-622, Parnell.

Philip Peacocke Limited AK. 112032. *Applicant:* D. B. Bendall, P.O. Box 3015, Auckland.

Seaton Enterprises Limited AK. 479921. *Applicant:* M. E. Judge, 2 Crown Hill Close, Milford.

Homeseekers (NZ) Limited AK. 532313. *Applicant:* C. Daalman, P.O. Box 99-681, Newmarket.

A.C.Naidu Holdings Limited AK. 377347. *Applicant:* Sanjay Sharma, P.O. Box 22-178, Otahuhu.

Campbell Resources Limited AK. 620022. *Applicant:* Ian Clarke, P.O. Box 31-368, Milford.

Tuson Fishing Limited AK. 550918. *Applicant:* A. Franklin, P.O. Box 7227, Wellesley Street, Auckland.

C.B.D. Apartments Limited AK. 837600. *Applicant:* Mike Worsnop, P.O. Box 5745, Auckland.

The Registrar proposes to act under section 330 of the Companies Act 1993, on the ground that the companies were carrying on business or in operation, or some other reason existed for the companies to remain on the Register at the time they were removed from the Register.

Any person who objects to the restoration of any of these companies to the Register must deliver a notice of that objection in writing to the District Registrar at Auckland within 20 working days of this notice.

Dated at Auckland this 27th day of August 1998.

NEVILLE HARRIS, Registrar of Companies.

The address for delivery of any notice is the Registrar, Fifth Floor, Justice Department Buildings, 3 Kingston Street, Auckland 1, or by post to Private Bag 92-061, Auckland.

ot6127

Notice of Intention to Restore Companies to the Register**The Companies Act 1993**

Take notice that the Registrar of Companies at Christchurch proposes to restore the following companies to the Register:

Assessment and Development Services Limited. *Applicant:* McKenzie Associates, P.O. Box 4244, Christchurch.

Greymouth Pharmacy Limited. *Applicant:* B. H. Connors, P.O. Box 369, Greymouth.

Bealey Investments Limited. *Applicant:* W. Galletly, 143 Maidstone Road, Ilam, Christchurch.

Swing Thru Canterbury Limited. *Applicant:* P. J. Aynsley, P.O. Box 20-298, Bishopdale, Christchurch.

Amateur Game Or Sport Promoter Limited. *Applicant:* Chapman Tripp Sheffield Young, P.O. Box 2510, Christchurch.

Hagley Developments Limited. *Applicant:* Paul Johnston, P.O. Box 664, Timaru.

B. Hosking Limited. *Applicant:* Williams & Batchelor, P.O. Box 8575, Riccarton, Christchurch.

Shearten Developments Limited. *Applicant:* J. K. Mehrtens, P.O. Box 8197, Riccarton, Christchurch.

The Registrar proposes to act, under section 328 (1) (a) of the Companies Act 1993, on the grounds that the companies were still carrying on in business or other reason existed for the companies to continue in existence at the time they were removed from the Register.

Any person who objects to the restoration of these companies to the Register must deliver notice of that objection to the Registrar in writing within 20 working days of the publication of this notice.

Contact Officer for Inquiries: Alice Yung, Ministry of Commerce, Business and Registries Branch, Private Bag 4714, Christchurch. Telephone: (03) 371 7008.

Dated at Christchurch this 20th day of August 1998.

NEVILLE HARRIS, Registrar of Companies.

ot6099

Corrigendum

Cancellation of Notice to Restore Company to the Register

Notice is given that the notice of intention to restore Medway River Vineyard Limited CH. 666329, which

appeared in the *New Zealand Gazette* on the 16th day of July 1998, appeared in error.

Dated at Christchurch this 18th day of August 1998.

NEVILLE HARRIS, Registrar of Companies.

ot6025

Land Transfer Act Notices

Land Transfer Act Notice

Application having been made to me, pursuant to section 44 of the Land Transfer Act 1952, to dispense with the production of certificate of title 10F/918 in the name of Grant Alexander Leith Robinson for the registration of the documents to deposit plan 76868, lodged under abstract under abstract A. 364452.2. Application A. 364452.1.

Notice is hereby given of my intention to register the above document upon the expiration of 14 days from the date of this publication.

Dated at the Christchurch Land Information New Zealand Office this 20th day of August 1998.

MICHAEL HART, District Land Registrar.

lt6049

Land Transfer Act Notice

I hereby give notice of my intention to issue new or provisional instruments of title in place of those declared lost and described in the Schedule below upon the expiration of 14 days from the date of this publication.

Schedule

(Certificate of title reference unless otherwise stated; registered proprietors name; application number.)

1. 335/70; Martyn McLean Smith and Karyn Margaret Smith; A. 363191.1.
2. Lease 414165.1; Bank of New Zealand; A. 363424.1.
3. 11K/1335 and mortgage A. 194879.2; Heather Jean Lavery; A. 363451.1.
4. 1C/1259; Margaret Jane Ford, David John Rayner and Gloria Frances Rayner; A. 363754.1.

Dated at the Christchurch Land Information New Zealand Office this 20th day of August 1998.

MICHAEL HART, District Land Registrar.

lt6050

Land Transfer Act Notice

I hereby give notice of my intention to issue new or provisional instruments of title in place of those declared lost and described in the Schedule below upon the expiration of 14 days from the date of this publication.

Schedule

(Certificate of title reference unless otherwise stated; registered proprietors name; application number.)

1. 5C/1394; Barry Francis Goodwin and Carole Florence O'Neil; 199243.1.
2. Mortgage 185032.3; Countrywide Banking Corporation Limited; 199243.1.

Dated at the Blenheim Land Information New Zealand Office this 18th day of August 1998.

IAN CASSIDY, for District Land Registrar.

lt6016

Land Transfer Act Notice

I hereby give notice of my intention to issue a provisional mortgage in place of those declared lost and described in the Schedule below upon the expiration of 14 days from the date of this publication.

Schedule

(Certificate of title reference unless otherwise stated; registered proprietors name; application number.)

1. 101828; the National Bank of New Zealand Limited; 199093.1.

Dated at the Blenheim Land Information New Zealand Office this 18th day of August 1998.

IAN CASSIDY, for District Land Registrar.

lt6017

Land Transfer Act Notice

I hereby give notice of my intention to issue new or provisional instruments of title in place of those declared lost and described in the Schedule below upon the expiration of 14 days from the date of the publication in the *New Zealand Gazette*.

Schedule

(Certificate of title reference unless otherwise stated; registered proprietors name; application number.)

1. Lease 288140; Denise Leslie Johnson; 675075.1.
2. G3/1059, G3/1062 and lease 331457.1; Mona Margaret Munro; 675318.1.
3. Lease 412313.2; Her Majesty the Queen; 674930.1.
4. L2/110; Klaas Albert Lourens de Lange and Mary Anne de Lange; 675302.1.
5. H4/902 and P4/1283; Cranleigh Farm Limited; 675129.1.
6. L2/965; Terence Joseph Hale and Moana Elaine Ngatai; 674928.1.
7. C1/595; John Warner Fannin and Barbara May Fannin; 674825.1.

Dated at the Napier Land Information New Zealand Office this 18th day of August 1998.

JULIE GARDNER, for District Land Registrar.

lt5972

Land Transfer Act Notice

I hereby give notice of my intention to issue new or provisional instruments of title in place of those declared lost and described in the Schedule below upon the expiration of 14 days from the date of this publication.

Schedule

(Certificate of title reference unless otherwise stated; registered proprietors name; application number.)

1. 93/147; Helen Patricia Jones; 379814.1.

Dated at the Nelson Land Information New Zealand Office this 20th day of August 1998.

SUE CROSS, for District Land Registrar.

lt6047

Land Transfer Act Notice

Application having been made to me, pursuant to section 44 of the Land Transfer Act 1952, to dispense with the production of the certificates of title 8D/1181, 1186 and 33A/300 for the registration of a transmission from James David Bertram Welch to Margaret Patricia Welch, lodged under B. 490831.1.

Application having been made to me, pursuant to section 44 of the Land Transfer Act 1952, to dispense with the production of the certificate of title 1064/119 for the registration of an application to register Housing New Zealand Limited as registered proprietor, lodged under B. 483846.1.

Notice is hereby given of my intention to register the above document upon the expiration of 14 days from the date of this publication.

Dated at the Hamilton Land Information New Zealand Office this 20th day of August 1998.

ROBERT ANDRELL, District Land Registrar.

lt6048

Land Transfer Act Notice

I hereby give notice of my intention to issue new or provisional instruments of title in place of those declared lost and described in the Schedule below upon the expiration of 14 days from the date of this publication.

Schedule

(Certificate of title reference unless otherwise stated; registered proprietors name; application number.)

1. 2D/1374; Stephen Crawford Miln and Tena Dorothy Miln; B. 494377.1.
2. 25A/965; Jessie Ann Stuart, Carrick John McPherson Stuart and Joanna Miller; B. 493959.1.
3. B. 395883; Jessie Ann Stuart, Carrick John McPherson Stuart and Joanna Miller; B. 493959.1.
4. H. 582707.49; Dawn Meredith; B. 494627.1.
5. H. 582707.50; Brian James Rodger and Merle Maureen Rodger; B. 494627.1.
6. 433/118; Terence William Booth and Maureen Margaret Lucy Booth; B. 494843.1.
7. 37B/996; Norma Doreen Millichip; B. 494757.1.
8. Lease S. 598272; Maxwell Charles Manton and Ruth Prescott Manton; B. 493644.1.
9. 44A/155; Percy Gilbert Phillips; B. 490851.2.
10. 8D/1181, 1186 and 33A/300; Margaret Patricia Welch; B. 490831.2.
11. 1064/119; Housing New Zealand Limited; B. 483846.2.

Dated at the Hamilton Land Information New Zealand Office this 20th day of August 1998.

ROBERT ANDRELL, District Land Registrar.

lt6052

Land Transfer Act Notice

Application having been made to me, pursuant to section 121 of the Land Transfer Act 1952, to note the re-entry of the lease set out in the Schedule below and that I intend to notify the re-entry upon the Register upon the expiration of 5 weeks from the date of this publication.

Schedule

1. Lease B. 316722.2 of lease B. 073657.2 of lease B. 073657.1 of lease H. 987793 over certificate of title 3D/606 of which the lessor is Hemingway Combines Limited and the lessees are Thomas McLinden and Peter Brogger Jorgensen. Application B. 487792.2.

Dated at the Hamilton Land Information New Zealand Office this 20th day of August 1998.

ROBERT ANDRELL, District Land Registrar.

lt6103

Land Transfer Act Notice

I hereby give notice of my intention to issue new or provisional instruments of title in place of those declared lost and described in the Schedule below upon the expiration of 14 days from the date of this publication.

Schedule

(Certificate of title reference unless otherwise stated; registered proprietors name; application number.)

1. 17D/226; Bruce Leslie Purvis, Robert Wayne Bowen, Karin Ngarie Bowen and Waihem Forests Limited; 952767.1.
2. 6B/1048; Ross Trevor Drummond and Beverley Christina Drummond; 951248.1.

Dated at the Dunedin Land Information New Zealand Office this 21st day of August 1998.

JOHN VAN BOLDEREN, District Land Registrar.

116051

Land Transfer Act Notice

I hereby give notice of my intention to issue new or provisional instruments of title in place of those declared lost and described in the Schedule below upon the expiration of 14 days from the date of the publication in the *New Zealand Gazette*.

Schedule

(Certificate of title reference unless otherwise stated; registered proprietors name; application number.)

1. 19C/374 and lease 271497.3; Magdalene Munro Martin; B. 676529.1.
2. 41C/421; Shane Williams and Deborah Mary Williams; B. 670354.1.
3. 31C/207; Graham William Darlow and Virginia Janet Darlow; B. 676780.1.
4. Mortgage 894493.5; Dudley Stuart McFarlane and Dorothy Alethea McFarlane; B. 676780.1.
5. 31B/389 and lease 870340.1; Ian Leslie Reeves and Nicola Ann Lynch-Reeves; B. 676505.1.
6. 22D/128; David Andrew Bennet and Catherine Margaret Bennet; B. 676943.1.
7. 12A/1454; Gwendoline Berry Boyden; B. 676982.1.
8. 48D/242; Karen Diane Hansen; B. 677039.1.

Dated at the Wellington Land Information New Zealand Office this 20th day of August 1998.

WARREN MOYES, District Land Registrar.

116030

Land Transfer Act Notice

I hereby give notice of my intention to issue new or provisional instruments of title in place of those declared lost and described in the Schedule below upon the expiration of 14 days from the date of this publication.

Schedule

(Certificate of title reference unless otherwise stated; registered proprietors name; application number.)

1. C3/75; Mary Athalie Roebuck; 453496.1.
2. 254/40; Peter Kaahu Marshall and Gail Lillian Marshall; 452740.1.

Dated at the New Plymouth Land Information New Zealand Office this 21st day of August 1998.

G. D. O'BYRNE, for District Land Registrar.

116100

Land Transfer Act Notice

1. Application having been made to me, pursuant to section 44 of the Land Transfer Act 1952, to dispense with production of the certificate of title 1347/75 for the deposit

of Plan 186537 and the issuing of the certificates of title for Lots 1 and 2 on the said plan whereby Larry Charles Moore and Janice Moore are the registered proprietors. Application D. 302178.

2. Application having been made to me, pursuant to section 44 of the Land Transfer Act 1952, to dispense with production of lease B. 203064.1 for the surrender of same and the issuing of the certificate of title for Flat 1, Deposited Plan 187671, whereby Brian Lawrence Smith and Janet Ruby Smith are the registered proprietors. Application D. 295744.

3. Application having been made to me, pursuant to section 44 of the Land Transfer Act 1952, to dispense with production of the certificate of title 82C/43 for the deposit of Plan 138037 and the issuing of the certificate of title for Unit B on the said plan whereby Ronald Watson Webster and Wendy Eileen Webster are the registered proprietors. Application D. 303498.

Notice is hereby given of my intention to register the above document upon the expiration of 14 days from the date of this publication.

Dated at the Auckland Land Information New Zealand Office this 20th day of August 1998.

D. A. CHAPMAN, District Land Registrar.

116101

Land Transfer Act Notice

I hereby give notice of my intention to issue new or provisional instruments of title in place of those declared lost and described in the Schedule below upon the expiration of 14 days from the date of this publication.

Schedule

(Certificate of title reference unless otherwise stated; registered proprietors name; application number.)

1. Mortgage C. 650475.5; Post Office Bank Limited; D. 301718.
2. 298/82; David John Bowater; D. 301932.
3. 76C/290; David Arthur James Light and Susan Linda Joy Light; D. 302010.
4. Lease C. 509145.1; Larry Charles Moore and Janice Moore; D. 302178.
5. 15A/207; Lila Ilohahia; D. 302188.
6. Lease B. 708945.3; Deborah Susan Hay; D. 302195;
7. 42C/463; Adamson (Taipa) Limited; D. 302247.
8. Lease 603587.3; Ruby Maud Rowland; D. 302333.
9. Lease A. 264446 and 13D/944; Dora Southgate; D. 302656.
10. 35B/889; Peter Alexander Waddell; D. 302851.
11. Leases 12924 and 12925; The New Zealand Insurance Company Limited; D. 302853.
12. 115D/395; Philip David Massicks and Barbara Anne Andrewes; D. 302935.
13. 71C/536; Wyn Logan Brooks, Roger Hamilton Brooks and Wendy Juliet Pryde; D. 303060.
14. Lease A. 300415; Michael George Millett and Alison Esther Millett; D. 303086.
15. Lease B. 280265.4; Elizabeth Mary Stark; D. 303143.
16. 4B/420; John Ah Sam and Annie Marion Ah Sam; D. 303407.
17. Lease B. 452266.1; Raymond Leslie Ryan and Pauline Anne Ryan; D. 303449.

18. Mortgage D. 205619.2; Countrywide Banking Corporation Limited; D. 303486.

19. 36D/621; Donald George Rewita and Christina Julia Rewita; D. 303486.

Dated at the Auckland Land Information New Zealand Office this 20th day of August 1998.

D. A. CHAPMAN, District Land Registrar.

lt6102

Land Transfer Act Notice

I hereby give notice of my intention to issue new or provisional instruments of title in place of those declared lost and described in the Schedule below upon the

expiration of 14 days from the date of the publication in the *New Zealand Gazette*.

Schedule

(Certificate of title reference unless otherwise stated; registered proprietors name; application number.)

1. Lease 191998.1; Best Friend Pet Foods Limited; 221533.2.

Dated at the Gisborne Land Information New Zealand Office this 21st day of August 1998.

A. PRIEBEE, for District Land Registrar.

lt6104

Charitable Trusts Act Notices

New Zealand School of Dance

Notice of Approval of Scheme

Notice is hereby given, pursuant to section 54 of the Charitable Trusts Act 1957, that on the 4th day of May

1998, the High Court at Wellington approved a scheme under Part III of the Charitable Trust Act 1957, varying the trust deed of the New Zealand School of Dance.

ct6065

Friendly Societies and Credit Unions Act Notices

Totara Lodge

Advertisement of Dissolution

Notice is hereby given that the Registrar of Friendly Societies and Credit Unions will, pursuant to section 94 of the Friendly Societies and Credit Unions Act 1982, register an instrument of dissolution of Totara Lodge, a branch of the Druids Friendly Society (North Island) NZ (in liquidation), unless within 3 months from the date of the *New Zealand Gazette* in which this advertisement appears, a member or other person interested in or having any claim

on the funds of the lodge commences proceedings to set aside the dissolution, and the dissolution is set aside accordingly.

Further details are available from the Registrar of Friendly Societies, Private Bag 5901, Lambton Quay, Wellington. Telephone: (04) 495 1261.

W. K. SLOAN, Registrar.

fs6015

Departmental Notices

Agriculture and Forestry

Veterinarians Act 1994

Appointment of a Non Veterinarian to the Veterinary Council of New Zealand

Pursuant to section 45 (b) of the Veterinarians Act 1994, I hereby appoint

Pauline Govenlock

to be a non veterinarian member of the Veterinary Council of New Zealand for a term from the date of notification in the *New Zealand Gazette*, expiring 31 December 2000.

Dated at Wellington this 21st day of July 1998.

A. L. SMITH, Minister of Agriculture.

go6038

Conservation

Conservation Act 1987

Establishment of Conservation Boards and Appointment of Members and Chairpersons to Conservation Boards

Pursuant to section 6L of the Conservation Act 1987, I, Nicholas Rex Smith, Minister of Conservation, hereby establish the following Conservation Boards from 1 September 1998 and pursuant to sections 6P and 6R of the Conservation Act 1987, I appoint the persons named hereunder to serve as members of the said boards from 1 September 1998 until the date specified and pursuant to section 6S of the Conservation Act 1987, I appoint the persons named hereunder as chairpersons of the said boards for a term of 1 year from 1 September 1998. The North Canterbury, Aoraki, Nelson, Marlborough and Rangitikei-Hawke's Bay Conservation Boards established by *Gazette* notice on 4 October 1996 are disestablished from and inclusive of 1 September 1998.

Northland Conservation Board

<i>Members Appointed</i>	<i>Occupation</i>	<i>Term</i>
Richard Alspach of Dargaville	Farmer	01/09/1998 to 31/08/2001
Richard John Drake of Tangiteroria	Farmer	01/09/1998 to 31/08/1999
Arapeta Hamilton of Paihia	Manager	01/09/1998 to 31/08/1999
Gloria Hareruia Herbert of Broadwood	Iwi consultant	01/09/1998 to 31/08/1999
Vincent Carlyle Kerr of Whangarei	Ecologist	01/09/1998 to 31/08/2000
Roger Thomas Mulvay of Matakoho	General manager	01/09/1998 to 31/08/2000
Maxine Khrona Shortland of Russell	Teacher	01/09/1998 to 31/08/2001
Janet Rhona Stephenson of Omapere	Planning consultant	01/09/1998 to 31/08/2001
Janis Wiki Walker of Moerewa	Mediator	01/09/1998 to 31/08/2000
Chairperson: Richard John Drake of Northland	Farmer	01/09/1998 to 31/08/1999

Auckland Conservation Board

<i>Members Appointed</i>	<i>Occupation</i>	<i>Term</i>
William (Bill) Andrew Maxwell Burrill of Papatoetoe	Farmer	01/09/1998 to 31/08/1999
David Ralph Eliot Chandler of Mount Roskill	Retired	01/09/1998 to 31/08/1999
Anne Fenn of Mount Roskill	Self employed	01/09/1998 to 31/08/2000
Melvyn (Mel) Peter Galbraith of Birkenhead	Teacher	01/09/1998 to 31/08/2001
Laly Paraone Haddon of Pakiri	Farmer/tourist operator	01/09/1998 to 31/08/2001
Grant Pakihana Hawke of Orakei	Environmental/resource management spokesperson	01/09/1998 to 31/08/2001
David Michael Hill of Titirangi	Resource management planning consultant	01/09/1998 to 31/08/2000
Graeme John Murdoch of Waitakere	Historian	01/09/1998 to 31/08/1999
Debra (Liane) Ngamane of Ponsonby	Student/resource management advisor	01/09/1998 to 31/08/1999
David Parker of Warkworth	Executive officer	01/09/1998 to 31/08/1999
Christine Anne Smith of Kumeu	Rodney district councillor	01/09/1998 to 31/08/2000
Mary Penelope (Penny) Webster of Wellsford	Farmer/teacher	01/09/1998 to 31/08/2001
Chairperson: David Michael Hill of Titirangi	Resource management planning consultant	01/09/1998 to 31/08/1999

Waikato Conservation Board*Members Appointed*

	<i>Occupation</i>	<i>Term</i>
Josephine (Josie) Marama Anderson of Paeroa	Chief executive officer	01/09/1998 to 31/08/1999
John Kenneth Ash of Waitomo	Tourist operator	01/09/1998 to 31/08/1999
Maurice (Ross) Bailey of Whangamata	Retired	01/09/1998 to 31/08/1999
Megan Ruby Balks of Hamilton	University lecturer	01/09/1998 to 31/08/2001
Beverley Rae Clarkson of Hamilton	Scientist	01/09/1998 to 31/08/2000
Sandra Goodwin of Tirau	Farmer	01/09/1998 to 31/08/2001
Graeme Donald Kilgour of Rotorua	Semi retired	01/09/1998 to 31/08/2000
Harold Maniapoto of Kihikihi	Managing director	01/09/1998 to 31/08/2000
Ratapu (Hori) te Awa of Huntly	Chief executive officer	01/09/1998 to 31/08/2001
Chairperson: Megan Ruby Balks of Hamilton	University lecturer	01/09/1998 to 31/08/1999

Bay of Plenty Conservation Board*Members Appointed*

	<i>Occupation</i>	<i>Term</i>
Donald Mairangi (Don) Bennett of Rotorua	Retired	01/09/1998 to 31/08/1999
Hilary Joan Gill of Rotorua	Retired	01/09/1998 to 31/08/2000
Philip John (John) Hohapata-Oke of Whakatane	Consultant	01/09/1998 to 31/08/1999
Herbert Arthur Ireland Madgwick of Rotorua	Retired	01/09/1998 to 31/08/2000
Robert Edward McGowan of Tauranga	Continuing education officer	01/09/1998 to 31/08/2000
Stanley Kevin (Kevin) Merriman of Tauranga	Farmer	01/09/1998 to 31/08/2000
Melanie Ann Moorcroft of Rotorua	Business consultant	01/09/1998 to 31/08/2001
Kihi Ngatai of Tauranga	Orchardist	01/09/1998 to 31/08/1999
Gaye Payze of Waimana	Planner	01/09/1998 to 31/08/2001
Rea Anne Rangihueua of Rotorua		01/09/1998 to 31/08/2001
Chairperson: Melanie Ann Moorcroft of Rotorua	Business consultant	01/09/1998 to 31/08/1999

Taranaki/Wanganui Conservation Board*Members Appointed*

	<i>Occupation</i>	<i>Term</i>
Laurence (Laurie) Joseph Abernethy of Taihape	Farmer	01/09/1998 to 31/08/2000
Barbara Joan Arnold of Palmerston North	Teacher	01/09/1998 to 31/08/1999
Barney Haami of Whanganui	Retired	01/09/1998 to 31/08/2000
Peter Horsley of Palmerston North	University lecturer	01/09/1998 to 31/08/1999
Rex Moore of New Plymouth	Public relations and marketing manager	01/09/1998 to 31/08/2000
Allen Kevin (Kevin) Phillips of New Plymouth	Farming executive	01/09/1998 to 31/08/2001
Diane Mary Kumea Ratahi of Opunake	Tribal advisor	01/09/1998 to 31/08/2001
Derek Norman Schulz of Wanganui	Service broker/conservation worker	01/09/1998 to 31/08/2001
Audrey Severinsen of Fielding	District councillor	01/09/1998 to 31/08/1999
Huirangi Waikerepuru of New Plymouth		01/09/1998 to 31/08/2000

Members Appointed

Chairperson: Rex Moore of New Plymouth

*Occupation*Public relations and marketing
manager*Term*01/09/1998 to
31/08/1999***Tongariro/Taupo Conservation Board****Members Appointed*

June Marion Baker of Taumarunui

Laura Elizabeth Dawson of Taupo

Kevin Richard Hackwell of Wellington

Michael Leslie Hucks of Taupo

Peter John Masters of Taupo

John Marsden Nankervis of Wellington

John Roy Newton of Turangi

Tumu te Heuheu of Taumarunui

Rakato te Rangiita of Taupo

Chairperson: Laura Elizabeth Dawson of Taupo

*Occupation*Part-time tutor/statistics
interviewer/farmer

Executive secretary

Director

Retired medical practitioner

Helicopter pilot

Solicitor

Retired

Paramount Chief, Ngati
Tuwhatetoa

Retired

Executive secretary

*Term*01/09/1998 to
31/08/200101/09/1998 to
31/08/199901/09/1998 to
31/08/199901/09/1998 to
31/08/200001/09/1998 to
31/08/200001/09/1998 to
31/08/199901/09/1998 to
31/08/200001/09/1998 to
31/08/200101/09/1998 to
31/08/200101/09/1998 to
31/08/1999***East Coast/Hawkes Bay Conservation Board****Members Appointed*

Albert Lloyd (Lloyd) Beech of Taradale

Vianney Gaye Douglas of Te Araroa

Ellen Celia Forch of Napier

Donald Roderick Herdman of Whakatane

Francis (Frank) Martin of Wairoa

Narena Olliver of Whakatane

Frances Sheila (Sheila) Robinson of Gisborne

Ross Maitland Russell of Gisborne

Korotau Basil Tamiana of Whakatane

Noreen Te Oiroa Taylor of Hastings

Aubrey Tokawhakaia Temara of Ruatahuna

Eileen Harriet von Dadelszen of Havelock North

Chairperson: Aubrey Tokawhakaia Temara of Ruatahuna

Occupation

Telecommunications engineer

Manager

Environmental monitoring
manager

Retired

Farmer

Writer

Retired historian

Retired

Self employed

Administrator

Managing director

Resource management
consultant/regional councillor

Managing director

*Term*01/09/1998 to
31/08/200101/09/1998 to
31/08/200001/09/1998 to
31/08/200101/09/1998 to
31/08/199901/09/1998 to
31/08/200001/09/1998 to
31/08/199901/09/1998 to
31/08/199901/09/1998 to
31/08/200001/09/1998 to
31/08/200101/09/1998 to
31/08/199901/09/1998 to
31/08/200001/09/1998 to
31/08/200101/09/1998 to
31/08/1999***Wellington Conservation Board****Members Appointed*

Diane Marie Anderson of Eketahuna

Te Akapikirangi Arthur of Porirua

Andrew John Bertram of Levin

Elizabeth Anne Burge of Carterton

Peter Spencer Bygate of Wellington

Michael James Crozier of Wellington

Occupation

Music teacher/district councillor

Retired

Sales engineer

Resource management planner

Retired

Professor

*Term*01/09/1998 to
31/08/200001/09/1998 to
31/08/200101/09/1998 to
31/08/199901/09/1998 to
31/08/200101/09/1998 to
31/08/200001/09/1998 to
31/08/2000

<i>Members Appointed</i>	<i>Occupation</i>	<i>Term</i>
John Christopher (Chris) Horne of Wellington	Self-employed contractor	01/09/1998 to 31/08/1999
George Rangitauira Mikaera of Masterton	Supervisor	01/09/1998 to 31/08/2001
Mary Patricia O'Keeffe of Wellington	Heritage consultant	01/09/1998 to 31/08/1999
Ani Parata of Paraparaumu	Community advocate	01/09/1998 to 31/08/2000
Chairperson: John Andrew Bertram of Levin	Sales engineer	01/09/1998 to 31/08/1999

Nelson/Marlborough Conservation Board

<i>Members Appointed</i>	<i>Occupation</i>	<i>Term</i>
Hugh Jason Canard of Nelson	Company director	01/09/1998 to 31/08/2000
Graeme David Coates of Blenheim	Marine biologist/environmental auditor	01/09/1998 to 31/08/2001
Andrew (Andy) Ian Dennis of Nelson	Writer/conservation consultant	01/09/1998 to 31/08/2000
Kathleen (Kath) Hemi of Blenheim	Retired	01/09/1998 to 31/08/1999
Susan Jennifer King of Blenheim	Horticulturist	01/09/1998 to 31/08/1999
Maurice Manawatu Jnr. of Kaikoura	Skipper	01/09/1998 to 31/08/2001
Robin (Rob) Manson of Takaka	Farmer	01/09/1998 to 31/08/2001
Peter Colin (Colin) McNab of Blenheim	Solicitor	01/09/1998 to 31/08/2000
Scott Fraser Nicol of Motueka	Outdoor instructor	01/09/1998 to 31/08/1999
Robyn Jane Reid of Wakefield	Chief executive	01/09/1998 to 31/08/2001
Darcia Solomon of Kaikoura	Housewife	01/09/1998 to 31/08/2000
Ropata Robert (Robert) Pinehia Stephens of Motueka	Managing director	01/09/1998 to 31/08/2001
Chairperson: Susan Jennifer King of Blenheim	Horticulturist	01/09/1998 to 31/08/1999

Canterbury Aoraki Conservation Board

<i>Members Appointed</i>	<i>Occupation</i>	<i>Term</i>
Wikitoria (Wiki) Suvia Baker of Temuka	Community worker	01/09/1998 to 31/08/2000
Kay Lenore Booth of Lincoln	Lecturer	01/09/1998 to 31/08/2000
Donald Robert Brown of Banks Peninsula	Fisherman	01/09/1998 to 31/08/1999
Terry Hope Donaldson of Christchurch	Business manager	01/09/1998 to 31/08/2001
James Alister Hay Guild of Darfield	Farmer	01/09/1998 to 31/08/2000
Alan Graeme Jolliffe of Christchurch	Associate dean	01/09/1998 to 31/08/2001
David Martin O'Connell of Christchurch	Administrator	01/09/1998 to 31/08/2001
Robert Peter (Peter) William Shutt of Timaru	Writer/editor	01/09/1998 to 31/08/1999
Barbara Joy Spurr of Rangiora	Secondary school science advisor	01/09/1998 to 31/08/1999
Ainslie Talbot of Christchurch	Freelance producer/director	01/09/1998 to 31/08/2000
Chairperson: James Alister Hay Guild of Darfield	Farmer	01/09/1998 to 31/08/1999

West Coast Tai Poutini Conservation Board

<i>Members Appointed</i>	<i>Occupation</i>	<i>Term</i>
Rob Brown of Christchurch	Photographer	01/09/1998 to 31/08/2001

Members Appointed

<i>Members Appointed</i>	<i>Occupation</i>	<i>Term</i>
Bruce Nevile Hamilton of Westport	Farmer	01/09/1998 to 31/08/1999
Alexander (Alex) Bruce Miller of Franz Josef	Commercial pilot	01/09/1998 to 31/08/2001
Helen Ngairie Rasmussen of Haast	Business person	01/09/1998 to 31/08/2001
June Avis Robinson of Hokitika	Retired/voluntary community worker	01/09/1998 to 31/08/1999
James Mason Russell of Hokitika	Researcher	01/09/1998 to 31/08/2000
Sarah Jayne Stokes of Westport	Environmental manager	01/09/1998 to 31/08/2000
Suzanne (Sue) Gail Thomson of Westport	Manager	01/09/1998 to 31/08/2000
Gillian Anne Williams of Greymouth	Company director	01/09/1998 to 31/08/1999
Chairperson: Bruce Nevile Hamilton of Westport	Farmer	01/09/1998 to 31/08/1999

Otago Conservation Board**Members Appointed**

<i>Members Appointed</i>	<i>Occupation</i>	<i>Term</i>
John Robert Beattie of Patearoa	Farmer	01/09/1998 to 31/08/2001
Leslie (Les) Hambleton Cleveland of Dunedin	Managing director	01/09/1998 to 31/08/1999
Gillian (Jill) Eileen Hamel of Dunedin	Archaeologist	01/09/1998 to 31/08/1999
Robyn Margaret Jebson of Queenstown	Marketing manager	01/09/1998 to 31/08/2001
Alan Francis Mark of Dunedin	Plant ecologist	01/09/1998 to 31/08/1999
Sheryl Moana Miller of Dunedin	Student	01/09/1998 to 31/08/2000
Mary Ruth Sutherland of Papatowai	Tourism operator	01/09/1998 to 31/08/2000
Gail Tewaru Tipa of East Taieri	Project manager	01/09/1998 to 31/08/2001
Gilbert van Reenen of Wanaka	Veterinary scientist/photographer	01/09/1998 to 31/08/2000
Chairperson: Alan Francis Mark of Dunedin	Plant ecologist	01/09/1998 to 31/08/1999

Southland Conservation Board**Members Appointed**

<i>Members Appointed</i>	<i>Occupation</i>	<i>Term</i>
Derek Alan Angus of Invercargill	Self employed	01/09/1998 to 31/08/1999
Susan (Sue) Mary Bennett of Te Anau	Farmer and environmental consultant	01/09/1998 to 31/08/1999
Jane Ruby Davis of Riverton	Retired	01/09/1998 to 31/08/2000
Margaret Anne Hopkins of Stewart Island	Business partner	01/09/1998 to 31/08/1999
Malcolm MacKenzie of Winton	Farmer	01/09/1998 to 31/08/2000
Roger Munro McNaughton of Invercargill	Farmer	01/09/1998 to 31/08/2001
John Robert Mills of Te Anau	Farmer	01/09/1998 to 31/08/2001
Jan Marie Riddell of Winton	Farmer/planning consultant	01/09/1998 to 31/08/2000
George Edward Ryan of Bluff	Retired	01/09/1998 to 31/08/2001
Chairperson: Jan Marie Riddell of Winton	Farmer/planning consultant	01/09/1998 to 31/08/1999

Chatham Islands Conservation Board**Members Appointed**

<i>Members Appointed</i>	<i>Occupation</i>	<i>Term</i>
Ian Athol Edward Atkinson of Upper Hutt	Scientist	01/09/1998 to 31/08/1999

<i>Members Appointed</i>	<i>Occupation</i>	<i>Term</i>
George Day of Chatham Island	Manager	01/09/1998 to 31/08/2001
Ann Elizabeth Hough of Chatham Island	Tutor	01/09/1998 to 31/08/2000
Kenneth John Lanauze of Pitt Island	Farmer	01/09/1998 to 31/08/1999
Norman James (James) Moffett of Pitt Island	Farmer	01/09/1998 to 31/08/2000
Geordie Murman of Chatham Island	Fisher	01/09/1998 to 31/08/2001
Philip Douglas Seymour of Chatham Island	Farmer	01/09/1998 to 31/08/2001
Elizabeth Ann Tuanui of Chatham Island	Farmer	01/09/1998 to 31/08/2001
Alison Turner of Chatham Island	Community worker	01/09/1998 to 31/08/2000
Chairperson: Elizabeth Ann Tuanui of Chatham Island	Farmer	01/09/1998 to 31/08/1999

Dated at Wellington this 26th day of August 1998.

NICK SMITH, Minister of Conservation.

go6023

Courts

Criminal Justice Act 1985

Notice of Confiscation of Motor Vehicle

Pursuant to section 84 (2) (a) of the Criminal Justice Act 1985, an order was made in the Papakura District Court on 7 July 1998, against **Ruru Ellis** for the confiscation of the following motor vehicle:

1988 Mitsubishi Galant, registration No. WR 1906.

S. BHANA, Deputy Registrar.

go5999

Notice of Confiscation of Motor Vehicle

Pursuant to section 84 (2) of the Criminal Justice Act 1985, an order was made in the Papakura District Court on 7 August 1998, against **Stephen John Lord** for the confiscation of the following motor vehicle:

1989 Holden Commodore, registration No. OH 2755.

S. BHANA, Deputy Registrar.

go6036

Notice of Confiscation of Motor Vehicle

Pursuant to section 84 (2) of the Criminal Justice Act 1985, an order was made in the Hastings District Court on 28 July 1998, against **Roimata Thompson** for the confiscation of the following motor vehicle:

Datsun 200B Stationwagon, registration No. JU 2618.

R. L. GARRICK, Deputy Registrar.

go6162

Notice of Confiscation of Motor Vehicle

Pursuant to section 84 (2) of the Criminal Justice Act 1985, an order was made in the Hastings District Court on 19 August 1998, against **Joseph Mathew Rutene Cooper** for the confiscation of the following motor vehicle:

Mazda 929, registration No. IB 1408.

R. L. GARRICK, Deputy Registrar.

go6084

Notice of Confiscation of Motor Vehicle

Notice is hereby given that the following vehicle has been confiscated, pursuant to section 84 (2) of the Criminal Justice Act 1985:

Make: Nissan

Model: Fairlady

Year: 1979

Registration No.: OL 7750

Owned By: **Robert Earl Coleman**

Any person having an interest in the above vehicle must advise particulars of that interest to the undersigned within 7 days of the publication of this notice.

A. R. ROSANOWSKI, Registrar.

District Court, Gore.

go6083

Order for Confiscation of Motor Vehicle

Pursuant to Section 84 of the Criminal Justice Act 1985

CRN: 8019021502

On the 18th day of August 1998 at the District Court at Hamilton, **Glen Richard Murphy** of 12 Edwin Street, Hamilton, was convicted and disqualified from holding or obtaining a motor driver's licence for 1 year from 20 August 1998, following his conviction on 18 August 1998 for an offence of driving with excess breath alcohol.

And in addition to the above-mentioned penalty, Judge L. E. Laing, has ordered that a

Familia motor vehicle, registration No. SR 4254

owned by the above-mentioned defendant, be forfeited to Her Majesty the Queen, pursuant to section 84 (4) of the Criminal Justice Act 1985.

The vehicle is to be surrendered to the Registrar, District Court, Hamilton, or a Bailiff of the District Court, Hamilton, by 12 noon on the 19th day of August 1998.

Dated at the District Court at Hamilton this 18th day of August 1998.

[L.S.]

P. LEVI, Deputy Registrar.

go6176

Order for Confiscation of Motor Vehicle

Pursuant to Section 84 of the Criminal Justice Act 1985

CRN: 8019017884-7

On the 12th day of August 1998 at the District Court at Hamilton, **Joseph Tamati Turner** of 49 Carlyle Street, Cambridge, was convicted and sentenced to 7 years imprisonment following his conviction on 14 July 1998 for an offence of aggravated robbery (4) and in addition to the above-mentioned penalty, Judge R. P. Wolff, has ordered that a

Holden motor vehicle, registration No. JC 9017

owned by the above-mentioned defendant, **Joseph Tamati Turner** be forfeited to Her Majesty the Queen, pursuant to section 84 (4) of the Criminal Justice Act 1985.

The vehicle is to be surrendered to the Registrar, District Court, Hamilton, or a Bailiff of the District Court, Hamilton, by 5 p.m. on the 12th day of August 1998.

Dated at the District Court at Hamilton this 12th day of August 1998.

[L.S.]

P. LEVI, Deputy Registrar.

go6177

Domestic Violence (Programmes) Regulations 1996

Notice of Appointment of Chairperson of the Southern Regional Approval Panel

Pursuant to section 48 of the Domestic Violence (Programmes) Regulations 1996, the Chief Executive is pleased to appoint

Dianne Marion France, Family Court Co-ordinator, Christchurch.

as chairperson of the Southern Regional Approval Panel for the period commencing on the date of this notice and expiring with the close of the 31st day of March 1999.

J. J. W. BAILEY, Chief Executive, Department for Courts.

go6167

Crown Law Office

Judicature Act 1908

Acting Judge of High Court Appointed

Pursuant to section 11A of the Judicature Act 1908, His Excellency the Governor-General, in the name and on behalf of Her Majesty the Queen, has been pleased to appoint

The Honourable Daniel Paul Neazor

to be an acting Judge of the High Court for a term of 12 months commencing on the 1st day of November 1998, a certificate having been signed by the Chief Justice and 3 other permanent Judges of the High Court that in their opinion it is necessary for the due conduct of the business of the Court that an acting Judge be appointed.

Dated at Wellington this 10th day of August 1998.

D. A. M. GRAHAM, Attorney-General.

go6039

Appointment of Temporary Judge of High Court

Pursuant to section 11 of the Judicature Act 1908, His Excellency the Governor-General, in the name and on behalf of Her Majesty the Queen, has been pleased to appoint

John Richard Wild, Q.C.

a temporary Judge of the High Court for a term of 12 months commencing on the 1st day of September 1998.

Dated at Wellington this 15th day of July 1998.

D. A. M. GRAHAM, Attorney-General.

go6040

Appointment of Temporary Judge Made Permanent

Pursuant to section 4 of the Judicature Act 1908, His Excellency the Governor-General, in the name and on behalf of Her Majesty the Queen, has been pleased to appoint

The Honourable Colin Maurice Nicholson

to be a Judge of the High Court to take effect on the 20th day of August 1998.

Dated at Wellington this 10th day of August 1998.

D. A. M. GRAHAM, Attorney-General.

go6041

Appointment of Temporary Judge of the High Court

Pursuant to section 11 of the Judicature Act 1908, His Excellency the Governor-General, in the name and on behalf of Her Majesty the Queen, has been pleased to appoint

Edward Taihakurei Junior Durie, Chief Judge of the Maori Land Court

a temporary Judge of the High Court for a term of 12 months commencing on the 23rd day of October 1998.

Dated at Wellington this 10th day of August 1998.

D. A. M. GRAHAM, Attorney-General.

go6042

Education

Education Act 1989

Establishment of a New School

Pursuant to section 146 of the Education Act 1989, I hereby establish a primary school to be known as

Doncaster Drive Primary School
at Papamoa, Tauranga.

Dated this 10th day of August 1998.

WYATT CREECH, Minister of Education.

go6161

The St Brendan's School, Upper Hutt, Board of Trustees Election Notice

Pursuant to clause 9(1) of the Sixth Schedule to the Education Act 1989, and acting with authority delegated by the Minister of Education, I hereby validate an irregularity in the election of parent representatives for the St Brendan's School Board of Trustees. I have decided that the irregularity could not have materially affected the result of the election.

This notice takes effect on the day after its notification in the *New Zealand Gazette*.

Dated at Wellington this 21st day of August 1998.

ANNE DEVONSHIRE, Acting Senior Manager, National Operations.

go6159

The Correspondence School Board of Trustees Election Validation Notice

Pursuant to clause 9(1) of the Sixth Schedule to the Education Act 1989, and acting with authority delegated by the Minister of Education, I hereby validate an omission in the election of parent representatives for the Correspondence School Board of Trustees. I have decided that the omission could not have materially affected the result of the election.

This notice takes effect on the day after its notification in the *New Zealand Gazette*.

Dated at Wellington this 21st day of August 1998.

ANNE DEVONSHIRE, Acting Senior Manager, National Operations.

go6160

Private Schools Conditional Integration Act 1975

Supplementary Integration Agreement

Pursuant to section 10 of the Private Schools Conditional Integration Act 1975, notice is given that a supplementary integration agreement has been signed between the Minister of Education on behalf of Her Majesty the Queen, acting through the Senior Manager, National Operations, Ministry of Education, pursuant to delegated authority, and the proprietor of the following school:

Chanel College, Masterton.

The said supplementary integration agreement was executed on the 21st day of August 1998. A copy of the supplementary integration agreement is available for inspection without charge by any member of the public at

the district office of the Ministry of Education, 65 Waterloo Road, Lower Hutt.

Dated at Wellington this 21st day of August 1998.

ANNE DEVONSHIRE, Acting Senior Manager, National Operations.

go6157

Supplementary Integration Agreement

Pursuant to section 10 of the Private Schools Conditional Integration Act 1975, notice is given that a supplementary integration agreement has been signed between the Minister of Education on behalf of Her Majesty the Queen, acting through the Senior Manager, National Operations, Ministry of Education, pursuant to delegated authority, and the proprietor of the following school:

St Joseph's School, New Plymouth.

The said supplementary integration agreement was executed on the 21st day of August 1998. A copy of the supplementary integration agreement is available for inspection without charge by any member of the public at the district office of the Ministry of Education, 116 Victoria Avenue, Wanganui.

Dated at Wellington this 21st day of August 1998.

ANNE DEVONSHIRE, Acting Senior Manager, National Operations.

go6158

Fisheries

Fisheries Act 1983

Fisheries (Quota Aggregation Limit Exemption) Notice (No. 5) 1998 (No. F96)

Pursuant to section 28w (3) of the Fisheries Act 1983, the Minister of Fisheries, after consultation with the New Zealand Fishing Industry Board and the Treaty of Waitangi Fisheries Commission and after having regard to the provisions of section 28w (5) of the Fisheries Act 1983, hereby gives the following notice:

Notice

1. Title and commencement—(a) This notice may be cited as the Fisheries (Quota Aggregation Limit Exemption) Notice (No. 5) 1998.

(b) This notice shall come into effect on the day after its notification in the *New Zealand Gazette* and shall expire on the 20th day of December 1998.

2. Interpretation—In this notice, "Southern Scallop Fishery" has the meaning ascribed to it in section 2 of the Fisheries Act 1983.

3. Exemption to quota aggregation limit—(1) As from the date that this notice comes into effect, the Challenger Scallop Enhancement Company Limited is permitted to hold quota in excess of the 20 percent aggregation limit as provided for the Southern Scallop Fishery, up to an aggregation limit of 100 percent.

(2) As from the date that this notice comes into effect, the directors of the Challenger Scallop Enhancement Company Limited are permitted to hold quota and interest in quota in excess of the 20 percent aggregation limit for the Southern Scallop Fishery as provided in section 28w (1) of the Fisheries Act 1983, up to a limit of 100 percent.

Directors

Bennett, Ronald Franklyn

Brown, Murray Lamont
 Clark, Barry James
 Elkington, James Hemi
 Falconer, Brian
 Guard, Christopher Colin
 Parris, Christopher Robin
 Talley, Peter Ivan
 Te Miha, Frederick
 Thompson, Ivan Oliver

Dated at Wellington this 25th day of August 1998.

HON. JOHN LUXTON, Minister of Fisheries.

g06175

Fisheries (South Island Customary Fishing) Notice 1998 (No. F95)

Pursuant to regulation 9 of the Fisheries (South Island Customary Fishing) Regulations 1998, the Minister of Fisheries hereby gives the following notice.

Notice

1. Title and commencement—(1) This notice may be cited as the Fisheries (South Island Customary Fishing) Notice 1998.

(2) This notice shall come into effect the day after the date of its notification in the *New Zealand Gazette*.

2. Interpretation—In this notice:

(a) The term “Customary food gathering” has the same meaning as defined in the Fisheries (South Island Customary Fishing) Regulations 1998.

(b) Any reference to “Tangata Tiaki/Kaitiaki” means the person or persons appointed under regulation 9 of the

Fisheries (South Island Customary Fishing) Regulations 1998 as Tangata Tiaki/Kaitiaki for a general customary food gathering area/rohe moana.

3. Nomination of Tangata Tiaki/Kaitiaki—Te Hapu o Ngati Wheke Rapaki, being the tangata whenua holding manawhenua manamoana over the area from Heathcote Bridge and Port Levy to Waihora (area of the 1849 Port Cooper Deed), have nominated Wiremu Gillies and Henry Couch as Tangata Tiaki/Kaitiaki for the area from the Heathcote River Outlet to Adderley Head, including the whole of Lyttelton Harbour.

4. Appointment of Tangata Tiaki/Kaitiaki—The Minister of Fisheries hereby confirms the appointment of Wiremu Gillies and Henry Couch as Tangata Tiaki/Kaitiaki for managing customary food gathering from the Heathcote River outlet to Adderley Head; including the whole of Lyttelton Harbour. The appointment is for a term of 5 years commencing the day this notice comes into effect.

5. Power to authorise taking of fisheries resources for customary food gathering—The Tangata Tiaki/Kaitiaki appointed under these regulations may authorise any individual to take fisheries resources managed under the 1983 and 1996 Fisheries Acts for customary food gathering purposes from within the whole or any part of the above area. No customary food gathering of these resources may take place in this area without authorisation from the Tangata Tiaki/Kaitiaki.

Dated at Wellington this 19th day of August 1998.

HON. JOHN LUXTON, Minister of Fisheries.

g05698

Health

Medicines Act 1981

Renewal of Provisional Consent to the Distribution of a New Medicine

Pursuant to section 23 of the Medicines Act 1981, the Minister of Health hereby provisionally consents to the sale, supply or use in New Zealand of the new medicine set out in the Schedule hereto:

Schedule

<i>Name and Strength</i>	<i>Form</i>	<i>Name and Address of Manufacturer</i>	<i>Proprietary Name (if any)</i>
Danthron 5 mg/mL, poloxamer 40 mg/mL	Suspension, oral	Regent Laboratories Limited, North Acton, London, England; Universal Products Limited, Lytham, Lancashire, England and Douglas Pharmaceuticals Limited, Mount Wellington, Auckland.	Codalax
Danthron 15 mg/mL, poloxamer 200 mg/mL	Suspension, oral	Regent Laboratories Limited, North Acton, London, England; Universal Products Limited, Lytham, Lancashire, England and Douglas Pharmaceuticals Limited, Mount Wellington, Auckland.	Codalax Forte

Note: This consent is valid for 2 years from 30 July 1998.

Dated this 20th day of August 1998.

G. R. BOYD, Chief Advisor, Regulation and Safety, pursuant to delegation given by the Minister of Health on the 20th day of February 1997.

g06092

Classification of Medicines

Pursuant to section 106 (1) of the Medicines Act 1981, I, G. R. Boyd, Chief Advisor, Regulation and Safety, hereby declare the following:

1. The medicines listed in Schedule 1 to this notice are classified as prescription medicines.
2. The medicines listed in Schedule 2 to this notice are classified as restricted medicines.
3. The medicines listed in Schedule 3 to this notice are classified as pharmacy-only medicines.

Every reference to a medicine in this notice applies whether the medicine is synthetic in origin or is from biological or mineral sources.

Unless specific reference is made otherwise, every reference applies also to medicines that are—

- (a) Preparations and admixtures containing any proportion of any substance listed in the notice;
- (b) Salts and esters of any substance listed in the notice;
- (c) Preparations or extracts of biological materials listed in the notice;
- (d) Salts or oxides of elements listed in the notice.

Where any reference is modified by a statement of the strength of the medicine, the strength is calculated using the free acid, base, alcohol or element unless specifically stated otherwise.

Schedule 1

Prescription Medicines

astemizole
 basiliximab
 cerivastatin
 daclizumab
 desonide
 fluvoxamine
 grepafloxacin
 ibandronic acid
 imiquimod
 meloxicam
 mibefradil
 montelukast
 orlistat
 topotecan
 valsartan
 vinorelbine
 zolmitriptan
 zolpidem

Schedule 2

Restricted Medicines

amorolfine; for external use in medicines containing more than 0.25%
 flurbiprofen; in throat lozenges containing 10 milligrams or less per lozenge

Schedule 3

Pharmacy-only Medicines

amorolfine; for external use in medicines containing 0.25% or less

*ibuprofen; in liquid form for oral use in medicines which are sold in the manufacturer's original pack containing

200 millilitres or less in volume and in strengths of 100 milligrams or less per 5 millilitres

levocabastine

*Regulation 20 of the Medicines Regulations 1984 requires that all medicines sold without a practitioner's prescription must include a consumer information panel on the label. Further, all material changes to a medicine (including changes to labelling), must be notified to the Director-General of Health in accordance with section 24 of the Medicines Act 1981.

Dated this 18th day of August 1998.

G. R. BOYD, Chief Advisor, Regulation and Safety.

g06037

Internal Affairs

Burial and Cremation Act 1964

Burial and Cremation Act (Operational Service) Notice 1998

Pursuant to section 15 (2) of the Burial and Cremation Act 1964, the Minister of Internal Affairs gives the following notice.

Notice

1. Title and Commencement.—(1) This notice may be cited as the Burial and Cremation Act (Operational Service) Notice 1998.

2. This notice comes into force on the 28th day after the date of its notification in the *New Zealand Gazette*.

2. Operational Service.—The following service by members of Her Majesty's Forces is hereby declared to be "operational service" for the purpose of section 15 of the Burial and Cremation Act 1964.

1914–1918 War

Members of the New Zealand, Imperial and Allied Forces who served overseas or at home between 4 August 1914 and 31 August 1921. Included are service personnel who were attested for overseas service but did not proceed overseas; New Zealand service personnel who served in Home Service Units between 4 August 1914 and 31 August 1921; and those who served in the Merchant Navy in the waters of a war zone.

1939–1945 War

Members of the New Zealand, Commonwealth and Allied Forces who served overseas or at home between 3 September 1939 and 31 December 1947. Included are New Zealand service personnel who were attested for overseas service but did not proceed overseas; New Zealand service personnel who served in Home Service Units between 3 September 1939 and 31 December 1947; and those who served in the Merchant Navy in the waters of a war zone. Those who served in Japan with "J" Force between August 1945 and March 1949 also qualify.

Korean War

Members of the New Zealand, Commonwealth and Allied Forces who served in Korea or in Korean waters between 27 June 1950 and 27 July 1953.

The Malayan Emergency and Confrontation With Indonesia

Members of the New Zealand and Commonwealth Forces who served in the Federated States of Malaya, Malaysia, Singapore, Borneo, or in surrounding waters from 16 June 1948 to 1966. Personnel who served on operations on the

Thailand–Malaya border against Communist insurgents between 1960 and 1964.

The Vietnam War

Members of the New Zealand and Australian Armed Forces who served in Vietnam or in Vietnamese waters between 24 December 1962 and 24 December 1972.

Also eligible are those personnel of the United States of America, Korea and Thailand who defended the Republic of Vietnam, became New Zealand citizens and lived permanently in New Zealand immediately prior to their death.

The Gulf War

Members of the New Zealand Armed Forces who served in the operational area between 18 December 1990 and 13 April 1991.

Peacekeeping Service

United Nations Service in Angola between 10 October 1992 and 6 March 1993.

United Nations Service in the former Yugoslavia from 23 March 1992.

Dated at Wellington this 17th day of August 1998.

HON. JACK ELDER, Minister of Internal Affairs.

go6163

Gaming and Lotteries Act 1977

Permission to Conduct Within New Zealand a Lottery Promoted Outside New Zealand

Pursuant to section 69 of the Gaming and Lotteries Act 1977, I, Jack Elder, Minister of Internal Affairs, hereby permit Valvoline Australia Pty Limited, to conduct within New Zealand, subject to the conditions specified in the Schedule to this notice, a lottery promoted outside New Zealand as a sales promotion scheme, to promote the sale of the car cleaning and oil products.

Schedule

Conditions

The permission given by this notice is subject to the following conditions, namely:

- (1) Valvoline Australia Pty Limited, shall not conduct the sales promotion scheme in New Zealand after 30 November 1998;
- (2) The results of the sales promotion scheme shall be published in the *New Zealand Herald* on 12 December 1998; Winners will be notified by certified mail;
- (3) New Zealand winners shall not be subject to any extra cost when they claim their prizes;
- (4) The chance of a New Zealand participant winning a prize shall be equal to that of an overseas participant.

Dated at Wellington this 17th day of August 1998.

JACK ELDER, Minister of Internal Affairs.

go6000

Marriage Act 1955

Marriage (Approval of Organisations) Notice No. 11

Pursuant to the Marriage Act 1955, the Registrar-General of Marriages, hereby gives notice as follows:

Notice

1. This notice may be cited as the Marriage (Approval of Organisations) Notice No. 11.

2. The organisations specified in the Schedule hereto, are hereby declared to be an approved organisation for the purpose of the Marriage Act 1955.

Schedule

Alofa Tunoa Pentecostal Samoan Church Inc. in New Zealand.

Ananda Marga.

Harvest Time Christian Centre.

Dated at Lower Hutt this 25th day of August 1998.

B. E. CLARK, Registrar-General.

go6185

Marriage Celebrants for 1998 Notice No. 21

Pursuant to the provisions of section 10 of the Marriage Act 1955, the following names of marriage celebrants within the meaning of the said Act are published for general information:

Addley, Kevin George Benjamin, Church of Jesus Christ of Latter-Day Saints.

Ah Wong, Tommy Reynold, Church of Jesus Christ of Latter-Day Saints.

Allan, Roger, Jehovah's Witnesses.

Baker, Andrew John, New Life Churches of New Zealand.

Bridgford, Wallace, Christian Renewal Fellowship (Whangarei).

Burton, Patricia Ann, Keeping in Touch Christian Spiritualist Church.

Cathro, Grant Lomax, Brethren.

Christie, Deborah June, New Life Churches of New Zealand.

Donaldson, Alistair William, Brethren.

Erika, Etuati Eddie, Seventh-Day Adventist.

Exelby, Clive Douglas, New Life Churches of New Zealand.

Falconer, Mark Stephen, Seventh-Day Adventist.

Faletau, Siosateki Tonga, Church of the Messengers of the Gospel Inc.

Finau, Peni Paletua, Church of the Messengers of the Gospel Inc.

Gatoloa'i, Fi'a, Church of Jesus Christ of Latter-Day Saints.

George, Alan John Talbot, Baptist.

Harris, John Panico, Church of Jesus Christ of Latter-Day Saints.

Hata, Te Waiwhakaruru, Ringatu.

Henton, Graham John, New Life Churches of New Zealand.

Jupe, Albert Edward, Youth With a Mission New Zealand (Inc).

Kavana-George, Opati, Presbyterian.

Keach, Walter Murray Ross, Jehovah's Witnesses.

Lauvi, Meki, Congregational Christian Church of Samoa in New Zealand.

Le Sueur, Jason Michael, Church of Jesus Christ of Latter-Day Saints.

McCalla, David John, Jehovah's Witnesses.

McIntosh, James Bruce, Baptist.
 Martin, Arturo G., Church of Christ.
 Mason, Robert Keith, New Life Churches of New Zealand.
 Maxwell, Patuwahine, Ringatu.
 Mills, Ronald George, Presbyterian.
 Mitai, Ranginui, Ringatu.
 Morrison, Marcia, Roman Catholic.
 Nam, Woo-Taek, Han-Ou-Ri Korean Presbyterian Church of Auckland.
 Pugh, Gordon Thomas, Metropolitan Community Church in Christchurch.
 Setu, Pepe Mato, Assemblies of God in New Zealand.
 Sim, Fairlie Peter James, Presbyterian.
 Stone, Malin John, Church of Jesus Christ of Latter-Day Saints.
 Tai, Riini, Ringatu.
 Uila, Tamasone, Voice of Christ Full Gospel Church.
 Vailaau, Nove, Congregational Christian Church of Samoa in New Zealand.
 Vyle, Bruce William, Salvation Army.
 Williams, Jeffrey Glenn, Marlborough Bible Baptist Church.

Dated at Lower Hutt this 25th day of August 1998.

B. E. CLARK, Registrar-General.

go6186

Marriage Celebrants for 1998 Notice No. 22

Pursuant to the provisions of section 13 of the Marriage Act 1955, it is hereby notified that the following names have been removed from the list of marriage celebrants under section 10 of the Act:

Allen, Bernard George, Salvation Army.
 Browne, Graham George Fleming, Jehovah's Witnesses.
 Jone, Maaka Te Ao Muhurangi, Ringatu.
 Karana-George, Opati, Presbyterian.
 Kouka, Andrew, Jehovah's Witnesses.
 Northover, Joseph Tuahine, Ringatu.
 Pokere, Steven Tahurata, Church of Jesus Christ of Latter-Day Saints.
 Puke-Puke, Kimaro, Ringatu.
 Pulusi, Pulusi, Church of Jesus Christ of Latter-Day Saints.
 Robinson, Brian William, Church of Jesus Christ of Latter-Day Saints.
 Takuta, Tio, Ringatu.
 Tavui, Nu'umau Lata, Church of Jesus Christ of Latter-Day Saints.
 Viljoen, David Henry, Church of Jesus Christ of Latter-Day Saints.
 Von Benzon, Nicholas, Anglican.
 Waenga, Hemi, Ringatu.
 Wharepapa, Tamehana, Ringatu.
 Wikaira, Elliot Geoffrey, Church of Jesus Christ of Latter-Day Saints.

Dated at Lower Hutt this 25th day of August 1998.

B. E. CLARK, Registrar-General.

go6187

Marriage Celebrants for 1998 Notice No. 23

Pursuant to the provisions of section 11 of the Marriage Act 1955, the following names of marriage celebrants within the meaning of the said Act are published for general information:

Ayto, Ngaio, 41A Brown Street, Invercargill.
 Barradell, Eric Bernard, 2/2 Monde Place, Manukau City.
 Brennan, Garry Leslie, 16 Frostbite Place, Ranui, Waitakere City.
 Brownlie, Dennise Laura, Ararua Road, Matakoho.
 Candasamy, Satayvan Ramasamy, 70 Hair Street, Wainuiomata, Lower Hutt.
 Corbett, Suzanne, Te Rata, 8 The Strand, Waiwera, Hibiscus Coast, Auckland.
 Jo, Charles, 46 Port Waikato Road, Port Waikato, Tuakau.
 Law, Richard Alan, 11 Weld Street, Blenheim.
 Pool, Lilian Patricia, 185 Godley Road, Titirangi.
 Ryan, Terence John, 27 Barry Street, Christchurch.

Dated at Lower Hutt this 25th day of August 1998.

B. E. CLARK, Registrar-General.

go6188

Marriage Celebrants for 1998 Notice No. 24

Pursuant to the provisions of section 13 of the Marriage Act 1955, it is hereby notified that the following name has been removed from the list of marriage celebrants under section 11 of the Act:

Mihaere, Truby Tauroa, 2 Bell Street, Otane.

Dated at Lower Hutt this 25th day of August 1998.

B. E. CLARK, Registrar-General.

go6189

Patriotic and Canteen Funds Act 1947

Members of the Patriotic and Canteen Funds Board

Pursuant to section 4 of the Patriotic and Canteen Funds Act 1947, the Minister of Internal Affairs hereby appoints the following person to be a member of the New Zealand Patriotic and Canteen Funds Board for a period of 3 years commencing on the 1st day of January 1998.

Nominated by the New Zealand Patriotic and Canteen Funds Board

Mr Neville Alan Wallace of Howick.

Dated at Wellington this 1st day of April 1998.

HON. JACK ELDER, Minister of Internal Affairs.

go6168

Justice

Justices of the Peace Act 1957

Justice of the Peace Appointed

Pursuant to section 3 (1) of the Justices of the Peace Act 1957, His Excellency the Governor-General has been pleased to appoint the following persons to be Justices of the Peace for New Zealand:

Adams, Anne Elizabeth, 49 Munro Road, Ranui.
 Alaumri, Fatima, E/370 Saint Johns Road, Saint John, Auckland.
 Baigent, Henry David, 63 The Cliffs, Nelson.
 Brown, Linda Alana, 367 Titirangi Road, Titirangi.
 Brunton, Robert Donald, 16 Ruakaka Street, Hornby, Christchurch 8004.
 Clark, Raena, 34 Wilsher Crescent, Henderson.
 Clark, Susanna Moata, Takapau Road, P.O. Box 292, Waipukurau.
 Cowden, Cheryl Ann, 54 Averill Street, Shirley, Christchurch.
 Currie, Ian Wayne, 180D Dunford Place, Dunedin.
 Currie, John Bryce, 23 Gordon Street, Kurow, North Otago.
 Dever, Christopher Alan, 73 North Street, Palmerston North.
 Eggleton, Paul William, Camellia Cottage, 8 Grant Avenue, Russell, Bay of Islands.
 Faletau, Siosateki Tonga, 126 Preston Road, Otago.
 Foster, John Martin, 74 Lake Road, Devonport, Auckland.
 Gardner, Mark William, 12 Ogilvie Road, Gladstone, Greymouth.
 Gawith, Peter Wallace, Waikoukou Longbush, R.D. 4, Masterton.
 Gilchrist, Julie Anne, 2/33 Kiwi Street, Taupo.
 Godfrey, Rosina Dulcie Katharine, "Blue Ridge", 929 Main North Road, R.D. 1, Kaiapoi.
 Goodall, Robert Benjamin, 21 Tanoa Place, Glendene, Waitakere City.
 Grace, Judi Anne, 26A Cliff View Drive, Green Bay, Auckland.
 Harland, Catherine Joy, 20 Huapai Street, Onehunga, Auckland.
 Hawkins, Janice Marjorie, 30 Lakeside Drive, Papakura, Auckland.
 Henwood, Russell George, 18 Seddon Street, Rangiora, 8254.
 Herwini, Anne Inu, 501 Buckland Road, Pukekohe.
 Himona, Pani Albert, 119 Makora Road, Masterton.
 Hope, Ronald Keith, 801 Taumata Road, R.D. 3, Tauranga.
 Hornblow, John Charles, 36 Langston Avenue, Palmerston North.
 Huynh, Nhan Minh, 19 Pembroke Street, Papatoetoe, Auckland.
 Hyde, Denise Mary, 8 Mescal Street, Massey, Auckland.
 Impey, Melvyn John, 2 Hugh Brown Drive, New Lynn, Auckland 1007.

Lewis, John Anthony Botfield, 45A Byron Avenue, Takapuna, Auckland 1309.
 Lovell, Elizabeth Jean Bain, 115 Chapter Street, Saint Albans, Christchurch 5.
 Lowen, Cazna Beverly, 40 Walmer Road, Point Chevalier, Auckland.
 Macaulay, Yvonne Louisa, 10 Kenderdine Road, Elsthorpe, R.D. 2, Otane.
 Macfarlane, Anne Virginia, 23A Emmett Street, Herne Bay, Auckland.
 McGregor, Trevor Robert, 31A Matuhi Rise, Henderson, Auckland.
 McLean, Bertram Kairo, 31 Orion Place, Glenfield, Auckland.
 Meister, Prudence Katrina, 64 Trig Hill Road, Onetangi, Waiheke Island.
 Mitchell, Robert Edwards, 8 Toi Toi Place, Northcote, Auckland.
 Muir, William Ramsay, 499 No. 4 Road, R.D. 3, Te Puke.
 Mulligan, Trevor Frank, 18 Karaka Road, Whenuapai Village, Auckland.
 O'Neill, Barry John, 27 Augustine Street, Waimate.
 Palmer, Yvonne Shirley Ann, 124 Harewood Road, Christchurch.
 Papalii, Marjorie Rae, 204 Mount Albert Road, Sandringham, Auckland.
 Pearce, John Gordon Leonard, Oroua Road, R.D. 5, Palmerston North.
 Penn, Steve Joseph, 44 Muricata Avenue, Mount Maunganui.
 Purves, Linda, 112 Bexley Road, Bexley, Christchurch.
 Reeve, Gillian, 2/40 Gills Avenue, Papakura 1703.
 Robertson, Dennis, 33 Bainton Street, Bishopdale, Christchurch 5.
 Robertson, Stewart, Bakers Creek, Barrytown, Greymouth.
 Shaw, Earle Craig, 22D Yellowstone Crescent, Christchurch.
 Sherrard, Isabelle Mary, 1/41 Bolton Street, Blockhouse Bay, Auckland 7.
 Shivas, Dulcie May, 141 Jacks Pass Road, Hanmer Springs.
 Shuttlesworth, Murray Nelson, 118 Cunningham Crescent, Invercargill.
 Siulepa, Paul Toeieiu, 10 Ambler Avenue, Glen Eden, Auckland.
 Stuart, Elizabeth Maya, 10 Tinkler Place, Mangere, Auckland.
 Sturge, Peter Luton, 25 Paparoa Street, Christchurch.
 Tane, Philip Hapati, 7 Talavera Place, Te Atatu South, Auckland.
 Torrance, Alan Trevor Richman, 1215 Dominion Road, Mount Roskill, Auckland.
 Welch, Ngaire Kaye, 15 Clean Street, Te Kopuru.
 Wichman "Ngau, Eric Ngametua, 16A Aronui Terrace Kelston, Auckland 7.
 Williams, Mark Anthony, 209 Williams Road, Mangakuri Beach, R.D. 14, Havelock North.
 Wilson, Dianne Lesley, 3/24 Conference Street, Christchurch 8001.

Wilson, Donald Reid, 10 Dallas Street, Riverton.

Wong, Mary Elizabeth, 16 Manhattan Heights, Glendene, Auckland.

Wright, Anthony Gregory, 30 Main South Road, Upper Riccarton, Christchurch.

Wu, Gwo Shing (Parker), 5 Sunningvale Lane, Fendalton, Christchurch.

Dated at Wellington this 18th day of August 1998.

TONY RYALL, Associate Minister of Justice.

go6091

Oaths and Declarations Act 1957

Officers in the Marlborough District Council Authorised to Take Statutory Declarations

Pursuant to section 9 of the Oaths and Declarations Act 1957, I hereby authorise the holders for the time being of the offices in the service of the local authority specified in the Schedule below to take statutory declarations under the said Act.

Schedule

Marlborough District Council

Customer Services Co-ordinator.

Deputy Customer Service Co-ordinator.

Office Service Co-ordinator.

Human Resources Co-ordinator.

Dated at Wellington this 20th day of August 1998.

D. A. M. GRAHAM, Minister of Justice.

go6085

Officers in the Timaru District Council Authorised to Take Statutory Declarations

Pursuant to section 9 of the Oaths and Declarations Act 1957, I hereby authorise the holders for the time being of the offices in the service of the local authority specified in the Schedule below to take statutory declarations under the said Act.

Schedule

Timaru District Council

Employment Co-ordinator.

Senior Planning and Regulation Receptionist/Clerk.

Dated at Wellington this 20th day of August 1998.

D. A. M. GRAHAM, Minister of Justice.

go6166

Sale of Liquor Act 1989

Oamaru Licensing Trust General Election of Members Notice 1998

Pursuant to section 210 of the Sale of Liquor Act 1989, the Minister of Justice gives the following notice.

Notice

General Election of Members—The date for the general election for all the members of the Oamaru Licensing Trust is 10 October 1998.

Dated at Wellington this 20th day of August 1998.

DOUGLAS GRAHAM, Minister of Justice.

go6164

Ashburton Licensing Trust General Election of Members Notice 1998

Pursuant to section 210 of the Sale of Liquor Act 1989, the Minister of Justice gives the following notice.

Notice

General Election of Members—The date for the general election for all the members of the Ashburton Licensing Trust is 10 October 1998.

Dated at Wellington this 20th day of August 1998.

DOUGLAS GRAHAM, Minister of Justice.

go6165

Office of the Privacy Commissioner

Privacy Act 1993

Privacy Act Code of Practice Notice 1998

Pursuant to section 49 of the Privacy Act 1993, I give notice as follows:

1. The Health Information Privacy Code 1994 Amendment No. 3.

(a) was issued on 24 August 1998; and

(b) will come into force on 30 September 1998.

2. Copies of the amendment are available for inspection free of charge from the offices of the Privacy Commissioner, 20 Waterloo Quadrant, Auckland and 44–52 The Terrace, Wellington.

3. Copies of the amendment may be obtained free of charge from the offices of the Privacy Commissioner.

Dated this 24th day of August 1998.

B. H. SLANE, Privacy Commissioner.

go6178

Authorities and Other Agencies of State Notices

Civil Aviation Authority of New Zealand

Civil Aviation Act 1990

Airworthiness Directive

Pursuant to section 72i (3) (a) of the Civil Aviation Act 1990, and to a delegation from the Director of Civil Aviation, I, Geoffrey Neil Connor, Safety Analyst – Continuing Airworthiness, hereby issue the following airworthiness directives in respect of aircraft or aeronautical products:

DCA/AS350/50	DCA/AS355/3C	DCA/BN2/51A	DCA/BN2/54
DCA/DHC-1/140A	DCA/GLIDER/8B	DCA/M-4/6B	DCA/HU369/69B
DCA/R22/27B	DCA/R44/3B	DCA/SCH/143	DCA/SF/2
DCA/TUR/8C			

These airworthiness directives shall come into force on 28 August 1998.

These airworthiness directives may be viewed on the CAA website [www.caa.govt.nz], or at Aviation House, 1 Market Grove, Lower Hutt.

Dated this 24th day of August 1998.

GEOFFREY N. CONNOR, Safety Analyst–Continuing Airworthiness.

au6171

Summary of Exemptions Granted by the Director of Civil Aviation

Pursuant to section 37 of the Civil Aviation Act 1990, notification is hereby given of exemptions, set out in the Schedule hereto, granted by the Director of Civil Aviation.

Schedule

Docket 98/EXE/180

On 20 August 1998, to Brian Denis Dunn of Wellington, being the holder of a New Zealand certificate of registration, from the requirement in Civil Aviation Rule 47.101 (a) only in respect of De Havilland DH 92A Tiger Mother aircraft, registration ZK-ASV.

Notice of the grant, withdrawal or denial, of exemptions with provisos are published in the Civil Aviation Rules Register Information Leaflet (CARRIL), issue dated 27 August 1998. The CARRIL is available on the CAA website [www.caa.govt.nz]. Exemption files may also be viewed on prior request to the Registrar at the office of the Civil Aviation Authority, 1 Market Grove (P.O. Box 31-441), Lower Hutt.

Dated at Lower Hutt this 24th day of August 1998.

HILARY KEENAN, Docket Clerk.

au6170

Land Transport Safety Authority

Traffic Regulations 1976

Exemption From Specified Requirements of the Traffic Regulations 1976

Pursuant to regulation 90c (1) of the Traffic Regulations 1976, I, Peter Waring, Senior Engineer, hereby approve the LPG fuel system fitted to the motor vehicle specified in Schedule 1 of this notice, subject to the conditions specified within Schedule 2 of this notice.

Schedule 1

Vehicle Details

Make:	Locomobile
Year:	1900

Schedule 2

Conditions

- (i) This approval is only valid while the vehicle is owned and operated solely by Mr D. Shadbolt of Christchurch;
- (ii) This approval expires 10 years after its date of publication in the *New Zealand Gazette*.
- (iii) This approval may be revoked at any time.

Signed at Wellington this 6th day of August 1998.

P. WARING, Senior Engineer, acting under authority delegated to me by way of an instrument of delegation dated 18 December 1996.

au5985

Exemption From Specified Requirements of the Traffic Regulations 1976 and the Transport (Vehicle Standards) Regulations 1990

Pursuant to regulation 90 (1) of the Traffic Regulations 1976, and pursuant to regulation 36 of the Transport (Vehicle Standards) Regulations 1990, I, James Lindsay Graham Bell, Vehicle Compliance Officer, hereby exempt the motor vehicle specified in Schedule 1 of this notice from the requirements specified in Schedule 2, subject to the conditions specified in Schedule 3.

The notice in the *New Zealand Gazette*, No. 176 of 5 December 1996, page 4639, titled "Exemption From Specified Requirements of the Traffic Regulations 1976" and referenced as "au7891" is hereby revoked.

The notice in the *New Zealand Gazette*, No. 176 of 5 December 1996, page 4641, titled "Exemption From Specified Requirements of the Transport (Vehicle Standards) Regulations 1990" and referenced as "au7889" is hereby revoked.

Schedule 1**Vehicle Details**

Make: Lincoln
Model: Town Car
Year: 1984
VIN: ILNBP94FXBY633922

Schedule 2**Exempted Requirements**

Traffic Regulations 1976: Regulation 78A (c)
 Transport (Vehicle Regulation 29 (1) (c)
 Standards) Regulations 1990:

Schedule 3**Conditions**

- (i) This exemption relates only to the requirement for the fitting of a 3-point lap and diagonal seat belt for the left outer rearward facing seating position;
- (ii) A 2-point lap seat belt that complies with the appropriate vehicle standard is fitted for the left outer rearward seating position;
- (iii) All other sitting positions are fitted with the seat belts required by regulation 78A of the Traffic Regulations 1976 and regulation 29 of the Transport (Vehicle Standards) Regulations 1990;
- (iv) All seat belts must be in sound condition and good working order and must not be modified in any way;
- (v) All seat belts must be securely anchored to the vehicle and seat belt anchorages that are not the vehicle manufacturer's original equipment must comply with Specification St 120395;
- (vi) This exemption may be revoked at any time;
- (vii) A copy of this notice must be carried in the vehicle at all times and be readily available for inspection.

Signed at Wellington this 25th day of August 1998.

JAMES LINDSAY GRAHAM BELL, Vehicle Compliance Officer, acting under authority delegated to me by way of instrument of delegation dated 23 December 1996.

au6179

Exemption From Specified Requirements of the Traffic Regulations 1976

Pursuant to regulation 90 (1) of the Traffic Regulations 1976, I, John Richard Wolf, Vehicle Compliance Officer, hereby exempt the vehicle specified in Schedule 1 of this notice from the requirements of the Traffic Regulations 1976, listed in Schedule 2, subject to the conditions specified in Schedule 3.

Schedule 1**Vehicle Details**

Make: Nash
Model: Metropolitan
Year of Manufacture: 1956
VIN: 7A8DE000796207444

Schedule 2**Exempted Requirements**

Regulation 78 (1) (a) and (b)

Schedule 3**Conditions**

- (i) All seat belts must be in sound condition and good working order and must not be modified in any way;
- (ii) Approved 2-point lap seat belts are fitted in the front outboard sitting positions;
- (iii) This exemption may be revoked at any time;
- (iv) A copy of this notice must be carried in the vehicle at all times and must be readily available for inspection.

Signed at Auckland this 24th day of August 1998.

JOHN RICHARD WOLF, Vehicle Compliance Officer, acting under the authority delegated to me by way of instrument of delegation dated 23 December 1996.

au6180

Transport (Vehicle Standards) Regulations 1990**Exemption From Specified Requirements of the Transport (Vehicle Standards) Regulations 1990**

Pursuant to regulation 36 of the Transport (Vehicle Standards) Regulations 1990, I, Martyn Jacob de Liefde, Vehicle Compliance Officer, hereby exempt the motor vehicle specified in Schedule 1 of this notice from the requirements of the Transport (Vehicle Standards) Regulations 1990 listed in Schedule 2, subject to the conditions specified in Schedule 3.

Schedule 1**Vehicle Details**

Make: Ford
Model: Mustang
Year: 1967
Chassis No: 7T02C12208

Schedule 2**Exempted Requirements**

relating to:
 Regulation 29 (1) (c) and Rear seat belts
 (4):

Schedule 3**Conditions**

- (i) The items specified in Schedule 2 must be in sound condition and good working order;
- (ii) Two-point lap seat belts that comply with the appropriate vehicle standard are fitted in the rear outboard sitting positions;
- (iii) All seat belts must be securely anchored to the vehicle and seat belt anchorages that are not the vehicle manufacturer's original equipment must comply with Specification St120395;
- (iv) This exemption may be revoked at any time;
- (v) A copy of this notice must be carried in the vehicle at all times and be readily available for inspection.

Signed at Christchurch this 18th day of August 1998.

M. J. DE LIEFDE, Vehicle Compliance Officer, acting under the authority delegated to me by way of instrument of delegation dated 23 December 1996.

au5984

New Zealand Fire Service

Fire Service Act 1975

Dunedin Fire Districts Notice, August 1998

Pursuant to section 26 of the Fire Service Act 1975, the New Zealand Fire Service Commission hereby gives the following notice.

Notice

1. This notice may be cited as the Dunedin Fire District Notice, August 1998.
2. This notice shall come into force on the 27th day of August 1998.
3. This notice revokes and is in substitution for all previous fire district notices for the districts listed in the Schedule.

Constitution of Fire Districts

4. The urban areas of Dunedin City including the township of Mosgiel are hereby constituted as one fire district.
5. The boundaries of the constituted fire district are defined and delineated on a plan held at the Arapawa Fire Region Office, Wellington.

Schedule

Dunedin Fire District	Mosgiel Fire District
-----------------------	-----------------------

Dated at Wellington this 25th day of August 1998.

R. SAMPSON, National Commander, New Zealand Fire Service.

au5941

Securities Commission

Securities Amendment Act 1988

Designation Under Section 6 (1) (a) of the Securities Amendment Act 1988

Pursuant to section 6 of the Securities Amendment Act 1988, the Securities Commission gives notice that:

Bank of America National Trust & Savings Association is hereby designated as a person to whom paragraph (a) of subsection (1) of section 6 applies.

Dated at Wellington this 24th day of August 1998.

The common seal of the Securities Commission was hereunto affixed in the presence of:

[L.S.]

E. H. ABERNETHY, Chairman.

au6169

Land Notices

Conservation

Conservation Act 1987

Declaration That a Marginal Strip is Not Required

Pursuant to section 24B of the Conservation Act 1987, the Minister of Conservation hereby declares that the marginal strip requirements set out in section 24 of the Act, shall not apply in the case of the disposition of the land in the Schedule hereto.

Schedule

Canterbury Land District—Hurunui and Waimakariri Districts

1.4520 hectares, being Lots 1, 2, 3, 4, 5, 6 and 7, D.P. 60695, situated in Block IX, Grey Survey District.

Dated at Wellington this 5th day of August 1998.

NICK SMITH, Minister of Conservation.

(Files: DOC RO MAG 005)

ln6001

Authorisation of the Exchange of Land Held for Conservation Purposes (Stewardship Area) for Other Land

Pursuant to section 16A of the Conservation Act 1987, and to a delegation from the Minister of Conservation, the Northland Conservator, Department of Conservation, hereby authorises the exchange of land held for conservation purposes (stewardship area) described in the

First Schedule hereto, for the land described in the Second Schedule hereto.

First Schedule

North Auckland Land District—Far North District

3,996 square metres, more or less, being Allotment 266, Town of Mangonui, situated in Block V, Mangonui Survey District.

Second Schedule

North Auckland Land District—Far North District

607 square metres, more or less, being part closed road, shown marked "A" on S.O. 67343, situated in Block V, Mangonui Survey District.

Dated at Whangarei this 21st day of August 1998.

G. E. ROWAN, Northland Conservator.

(DOC File: O04.013)

ln6152

Notification of Disposal of Conservation Land

Pursuant to section 26 of the Conservation Act 1987, and to a delegation from the Minister of Conservation, the Community Relations Manager, Otago Conservancy, Department of Conservation, hereby declares that the land formerly held for conservation purposes described in the First Schedule hereto, has been disposed of for the consideration of three thousand nine hundred and thirty-seven dollars and fifty cents (\$3937.50) including G.S.T., and the land described in the Second Schedule hereto, has been disposed of for the consideration of twenty-nine thousand four hundred dollars (\$29,400.00) including G.S.T.

First Schedule**Otago Land District—Waitaki District**

9730 square metres, more or less, being Section 1, S.O. 24607, Block XIII, Town of Maheno. Certificate of title 18C/388.

Second Schedule

8.7964 hectares, more or less, being Section 1, S.O. 24408, Block III, Waikouaiti Survey District. Certificate of title 18B/781.

Dated at Dunedin this 14th day of August 1998.

I. R. H. WHITWELL, Community Relations Manager.

(DOC: LS 160, J42/11.02, SCE 60, I43/35.20)

ln6044

Declaration That Conservation Area Become a Scientific Reserve

Pursuant to section 8 (1A) of the Conservation Act 1987, and to a delegation from the Minister of Conservation, the Conservator of the Wellington Conservancy of the Department of Conservation, declares that the conservation area described in the Schedule hereto, shall hereafter be set apart as a reserve, subject to the Reserves Act 1977, and classified as a scientific reserve, subject to the provisions of the latter Act, to form part of the Makahika Scientific Reserve.

Schedule**Wellington Land District—Horowhenua District**

15.4270 hectares, more or less, being Lot 1, D.P. 79383, situated in Block III, Waiopahu Survey District, together with the right of way in transfer B. 499704.6. All C.T. 45D/821.

Dated at Wellington this 20th day of August 1998.

ALLAN ROSS, Conservator.

(Files DOC: G19/350)

ln6073

ICL

Harbour Boards Dry Land Endowment Revesting Act 1991**Land in Tauranga Declared to be a Reserve and to be Classified for Recreation Purposes**

MICHAEL HARDIE BOYS, Governor-General

ORDER IN COUNCIL

At Wellington this 24th day of August 1998

Present:

HIS EXCELLENCY THE GOVERNOR-GENERAL IN COUNCIL

Pursuant to section 4 (1) (c) of the Harbour Boards Dry Land Endowment Revesting Act 1991, His Excellency the Governor-General, acting with the advice and consent of the Executive Council, hereby declares the land vested in The Tauranga District Council and described in the Schedule, being part of the land referred to in Part C of the Schedule to the said Act as the "Tauranga City Marginal Strips", to be a reserve, classified for recreation purposes under the Reserves Act 1977, with effect from the 28th day after the date of publication of this Order in Council in the *New Zealand Gazette*.

Schedule**South Auckland Land District—Tauranga District**

3136 square metres, more or less, being Allotment 891, Section 2, Town of Tauranga, and being all the land comprised and described in certificate of title No. 13B/967, South Auckland Registry.

As shown on S.O. Plan 45362, lodged in the office of the Chief Surveyor at Hamilton.

MARIE SHROFF, Clerk of the Executive Council.

ln6172

Reserves Act 1977**Classification of Reserve and Vesting in the Napier City Council**

Pursuant to the Reserves Act 1977, and to a delegation from the Minister of Conservation, the Community Relations Manager, East Coast/Hawke's Bay Conservancy, classifies the reserve described in the Schedule as a local purpose (drainage) reserve and vests the reserve in The Napier City Council in trust for that purpose.

Schedule**Hawke's Bay Land District**

402 square metres, being Lot 13, Deposited Plan 4991 and being all the land in certificate of title 85/176.

Dated at Gisborne this 17th day of August 1998.

B. HUNT, Community Relations Manager, Department of Conservation, East Coast/Hawke's Bay Conservancy.

(DOC File: CO - RES 600)

ln6070

ICL

Declaration That Land is a Reserve

Whereas there is doubt whether the land described in the Schedule is reserve within the meaning of section 2 of the Reserves and Domains Act 1953, then pursuant to section 6 (1) of the Reserves Act 1977, and to a delegation from the Minister of Conservation, the Community Relations Manager, East Coast/Hawke's Bay Conservancy, declares that the land described in the Schedule is reserve within meaning of the Reserves Act 1977.

Schedule**Hawke's Bay Land District—Hastings District**

2.1162 hectares, more or less, being Section 1, S.O. 10879.

Dated at Gisborne this 17th day of August 1998.

B. HUNT, Community Relations Manager, Department of Conservation, East Coast/Hawke's Bay Conservancy.

(DOC File: CO - RES 601)

ln6071

ICL

Classification of Reserve and Vesting in the Hastings District Council

Pursuant to the Reserves Act 1977, and to a delegation from the Minister of Conservation, the Community Relations Manager, East Coast/Hawke's Bay Conservancy, classifies the reserve described in the Schedule as a local purpose (cemetery) reserve and vests the reserve in The Hastings District Council in trust for that purpose.

Schedule**Hawke's Bay Land District—Hastings District**

2.1162 hectares, more or less, being Section 1, S.O. 10879.

Dated at Gisborne this 17th day of August 1998.

B. HUNT, Community Relations Manager, Department of Conservation, East Coast/Hawke's Bay Conservancy.

(DOC File: CO - RES 601)

1CL

ln6072

Land Information New Zealand

Public Works Act 1981

Road to be Stopped and Vested, Outram Street, Napier City

Pursuant to sections 116 (1), 117 (3) of the Public Works Act 1981, and to a delegation from the Minister of Lands, Sarah Caroline Buchanan, Land Information New Zealand, declares the portion of road described in the Schedule to this notice (now known as Section 1, S.O. 10871), to be stopped and vested in The Napier City Council.

Schedule

Hawke's Bay Land District

Area m ²	Adjoining or passing through
------------------------	------------------------------

121 Part Lot 1, D.P. 21429, Lot 2, D.P. 25269 and Section 1, S.O. 10711; marked "A" on S.O. 10871.

Dated at Wellington this 12th day of August 1998.

SARAH BUCHANAN, for Minister of Lands.

(LINZ CPC/1998/526)

1CL

ln6045

Land Acquired for Road — Kirkwood/Omahu Roads, Hastings District

Pursuant to section 20 (1) of the Public Works Act 1981, and pursuant to a delegation from the Minister of Lands, Sarah Caroline Buchanan, Land Information New Zealand, declares that, an agreement to that effect having been entered into, the land described in the Schedule hereto, is hereby acquired for road, which shall vest in The Hastings District Council on the date of publication hereof in the *New Zealand Gazette*.

Schedule

Hawke's Bay Land District

1494 square metres, being Part Lot 4, D.P. 25325; as marked "A" on S.O. Plan 10783. (Part certificate of title W1/507).

Dated at Wellington this 18th day of August 1998.

SARAH CAROLINE BUCHANAN, for Minister of Lands.

(LINZ CPC/1998/190/A)

1CL

ln6046

Land Acquired for Drainage Works Westall Road, Waitakere City

Pursuant to section 20 (1) of the Public Works Act 1981, and to a delegation from the Minister of Lands, Sarah Buchanan, Land Information New Zealand, declares that an agreement to that effect having been entered into, the land described in the Schedule is hereby acquired for drainage works and shall vest in The Waitakere City Council on the date of publication of this notice in the *New Zealand Gazette*.

Schedule

North Auckland Land District

Area m ²	Being
------------------------	-------

2389 Part Lot 7, D.P. 53710; marked "A" on plan.
2078 Part Lot 1, D.P. 164944; marked "B" on plan.

Shown marked as above mentioned on S.O. 68411, lodged in the office of the Chief Surveyor at Auckland.

Dated at Wellington this 13th day of August 1998.

SARAH BUCHANAN, for Minister of Lands.

(LINZ CPC98/313A)

ln6078

Land Set Apart for Road in Waitakere City

Pursuant to section 52 of the Public Works Act 1981, and to a delegation from the Minister of Lands, Sarah Buchanan, Land Information New Zealand, declares the land described in the Schedule to this notice to be set apart for road and to remain vested in The Waitakere City Council.

Schedule

North Auckland Land District

Area m ²	Being
------------------------	-------

122 Part Lot 7, D.P. 53710; marked "A" on plan.
110 Part Lot 1, D.P. 164944; marked "B" on plan.

Shown marked as above mentioned on S.O. 69294, lodged in the office of the Chief Surveyor at Auckland.

Dated at Wellington this 14th day of August 1998.

SARAH BUCHANAN, for Minister of Lands.

(LINZ CPC98/313A)

ln6079

Declaration Acquiring Easements for Irrigation Purposes (Maungatapere Irrigation Scheme) Over Land in the Whangarei District

Pursuant to section 28 of the Public Works Act 1981, and to a delegation from the Minister of Lands, Sarah Caroline Buchanan, Land Information New Zealand, declares that, agreements to that effect having been entered into, rights to convey water over the land described in the First Schedule hereto, containing the rights and powers as contained in the Second Schedule hereto, are acquired for irrigation purposes for a term expiring on the 31st day of December 2050 and shall vest in the Crown on the date of publication of this notice in the *New Zealand Gazette*.

First Schedule

North Auckland Land District

Area m ²	Being
------------------------	-------

265 Part Lot 2, D.P. 154761; marked "J" on plan.
492 Part Lot 1, D.P. 32015; marked "L" on plan.

Shown marked as above mentioned on S.O. Plan 67534, lodged in the office of the Chief Surveyor at Auckland.

Second Schedule

The rights and powers contained in the Second and Fourth paragraphs of the Seventh Schedule of the Land Transfer Act 1952, as modified by the additional terms and conditions described in the agreements between Her Majesty the Queen and:

Owner	Dated	Certificate of Title
Peter Michael Radich and Gillian Kathleen Radich	31 October 1994	92B/998
Rosemary Anne Wilson	7 October 1994	885/99

copies of which can be sighted on the LINZ file mentioned below, and copies of which will be registered against the said certificates of title along with this notice.

Dated at Wellington this 17th day of August 1998.

SARAH BUCHANAN, for Minister of Lands.

(LINZ CPC/1998/570)

ln6080

Declaration Acquiring Easements for Irrigation Purposes (Maungatapere Irrigation Scheme) Over Land in the Whangarei District

Pursuant to section 28 of the Public Works Act 1981, and to a delegation from the Minister of Lands, Sarah Caroline Buchanan, Land Information New Zealand, declares that, agreements to that effect having been entered into, rights to convey water over the land described in the First Schedule hereto, containing the rights and powers as contained in the Second Schedule hereto, are acquired for irrigation purposes for a term expiring on the 31st day of December 2050 and shall vest in the Crown on the date of publication of this notice in the *New Zealand Gazette*.

First Schedule

North Auckland Land District

Area m ²	Being
422	Part Lot 1, D.P. 172914; marked "A" on plan.
57	Part Lot 1, D.P. 168954; marked "B" on plan.
324	Part Lot 1, D.P. 172914; marked "C" on plan.

Shown marked as above mentioned on S.O. Plan 67715; lodged in the office of the Chief Surveyor at Auckland.

Second Schedule

The rights and powers contained in the Second and Fourth paragraphs of the Seventh Schedule of the Land Transfer Act 1952, as modified by the additional terms and conditions described in the agreements between Her Majesty the Queen and:

Owner	Dated	Certificate of Title
Boyd Matson and Linda Maree Matson	23 December 1994	89C/916 (now 103A/159) and 91C/665 (now 105B/65)

copies of which can be sighted on the LINZ file mentioned below, and copies of which will be registered against the said certificates of title along with this notice.

Dated at Wellington this 17th day of August 1998.

SARAH BUCHANAN, for Minister of Lands.

(LINZ CPC/1998/569)

ln6081

Declaration Acquiring Easements for Irrigation Purposes (Maungatapere Irrigation Scheme) Over Land in the Whangarei District

Pursuant to section 28 of the Public Works Act 1981, and to a delegation from the Minister of Lands, Sarah Caroline Buchanan, Land Information New Zealand, declares that, agreements to that effect having been entered into, rights to

convey water over the land described in the First Schedule hereto, containing the rights and powers as contained in the Second Schedule hereto, are acquired for irrigation purposes for a term expiring on the 31st day of December 2050 and shall vest in the Crown on the date of publication of this notice in the *New Zealand Gazette*.

First Schedule

North Auckland Land District

Area m ²	Being
5674	Part Lot 1, D.P. 150668; marked "A" on plan.
2217	Part Lot 2, D.P. 150668; marked "B" on plan.
531	Part Lot 2, D.P. 148428; marked "C" on plan.

Shown marked as above mentioned on S.O. Plan 67737, lodged in the office of the Chief Surveyor at Auckland.

Second Schedule

The rights and powers contained in the Second and Fourth paragraphs of the Seventh Schedule of the Land Transfer Act 1952, as modified by the additional terms and conditions described in the agreements between Her Majesty the Queen and:

Owner	Dated	Certificate of Title
Gordon William Grant Breckon and Cherry Breckon	20 January 1995	89D/666 and 89D/667
Kirsty Anne Russell and Andre Lawrence Russell	1 May 1998	88B/254

copies of which can be sighted on the LINZ file mentioned below, and copies of which will be registered against the said certificates of title along with this notice.

Dated at Wellington this 17th day of August 1998.

SARAH BUCHANAN, for Minister of Lands.

(LINZ CPC/1998/568)

ln6082

Declaration Acquiring Easements for Irrigation Purposes (Maungatapere Irrigation Scheme) Over Land in the Whangarei District

Pursuant to section 28 of the Public Works Act 1981, and to a delegation from the Minister of Lands, Sarah Caroline Buchanan, Land Information New Zealand, declares that, agreements to that effect having been entered into, rights to convey water over the land described in the First Schedule hereto, containing the rights and powers as contained in the Second Schedule hereto, are acquired for irrigation purposes for a term expiring on the 31st day of December 2050 and shall vest in the Crown on the date of publication of this notice in the *New Zealand Gazette*.

First Schedule

North Auckland Land District

Area m ²	Being
927	Part Lot 1, D.P. 168118 (formerly Part Lot 2, D.P. 11727); marked "G" on plan.
1893	Part Lot 1, D.P. 26944; marked "H" on plan.
1494	Part Lot 1, D.P. 130596; marked "I" on plan.

Shown marked as above mentioned on S.O. Plan 67718, lodged in the office of the Chief Surveyor at Auckland.

Second Schedule

The rights and powers contained in the Second and Fourth paragraphs of the Seventh Schedule of the Land Transfer Act 1952, as modified by the additional terms and

conditions described in the agreements between Her Majesty the Queen and:

Owner	Dated	Certificate of Title
Gladys Mildred Nichols and Gerald Keith Nichols	24 December 1993	271/253 (now 102B/207)
Norman Henry Phillips and Joy Doreen Phillips	23 December 1994	90D/836
James Keith Thomas and Vanessa Anne Thomas	31 October 1994	76C/232 (now 109A/96)

copies of which can be sighted on the LINZ file mentioned below, and copies of which will be registered against the said certificates of title along with this notice.

Dated at Wellington this 18th day of August 1998.

SARAH BUCHANAN, for Minister of Lands.

(LINZ CPC/1998/593)

In6093

Declaration Acquiring Easements for Irrigation Purposes (Maungatapere Irrigation Scheme) Over Land in the Whangarei District

Pursuant to section 28 of the Public Works Act 1981, and to a delegation from the Minister of Lands, Sarah Caroline Buchanan, Land Information New Zealand, declares that, agreements to that effect having been entered into, rights to convey water over the land described in the First Schedule hereto, containing the rights and powers as contained in the Second Schedule hereto, are acquired for irrigation purposes for a term expiring on the 31st day of December 2050 and shall vest in the Crown on the date of publication of this notice in the *New Zealand Gazette*.

First Schedule

North Auckland Land District

Area
m² Being

216 Part Lot 5, D.P. 92730; marked "B" on plan.

Shown marked as above mentioned on S.O. Plan 67356, lodged in the office of the Chief Surveyor at Auckland.

Second Schedule

The rights and powers contained in the Second and Fourth paragraphs of the Seventh Schedule of the Land Transfer Act 1952, as modified by the additional terms and conditions described in the agreements between Her Majesty the Queen and:

Owner	Dated	Certificate of Title
Robert James Blanchard and Kathryn Joyce Blanchard	20 October 1994	91D/958

copies of which can be sighted on the LINZ file mentioned below, and copies of which will be registered against the said certificates of title along with this notice.

Dated at Wellington this 20th day of August 1998.

SARAH BUCHANAN, for Minister of Lands.

(LINZ CPC/1998/592)

In6096

Declaration Acquiring Easements for Irrigation Purposes (Maungatapere Irrigation Scheme) Over Land in the Whangarei District

Pursuant to section 28 of the Public Works Act 1981, and to a delegation from the Minister of Lands, Sarah Caroline Buchanan, Land Information New Zealand, declares that, agreements to that effect having been entered into, rights to

convey water over the land described in the First Schedule hereto, containing the rights and powers as contained in the Second Schedule hereto, are acquired for irrigation purposes for a term expiring on the 31st day of December 2050 and shall vest in the Crown on the date of publication of this notice in the *New Zealand Gazette*.

First Schedule

North Auckland Land District

Area m ²	Being
700	Part Allotment 156, Maungatapere Parish; marked "A" on plan.
440	Part Allotment 46, Maungatapere Parish; marked "B" on plan.
506	Part Allotment 156, Maungatapere Parish; marked "C" on plan.
81	Part Allotment N54, Maungatapere Parish; marked "D" on plan.
513	Part Allotment 227, Maungatapere Parish; marked "E" on plan.
1425	Part Allotment 47, Maungatapere Parish; marked "F" on plan.

Shown marked as above mentioned on S.O. Plan 67535, lodged in the office of the Chief Surveyor at Auckland.

Second Schedule

The rights and powers contained in the Second and Fourth paragraphs of the Seventh Schedule of the Land Transfer Act 1952, as modified by the additional terms and conditions described in the agreements between Her Majesty the Queen and:

Owner	Dated	Certificate of Title
Valerie Anne Johnstone	7 October 1994	1187/73
Lester Donald Ruben Johnstone	7 October 1994	1187/72, 305/318 and 555/147 (now 46C/1107)

copies of which can be sighted on the LINZ file mentioned below, and copies of which will be registered against the said certificates of title along with this notice.

Dated at Wellington this 17th day of August 1998.

SARAH BUCHANAN, for Minister of Lands.

(LINZ CPC/1998/584)

In6097

Road Realignment in Franklin District—State Highway No. 1, Pokeno

Pursuant to the Public Works Act 1981, and to a delegation from the Minister of Lands, Sarah Caroline Buchanan, Land Information New Zealand:

(a) Pursuant to section 20 (1), and to section 88 (2) of the Transit New Zealand Act 1989, declares that, pursuant to an agreement to that effect having been entered into, the land described in the First Schedule to this notice is hereby acquired for a limited access road, which becomes road, limited access road and State highway and is vested in the Crown on the date of publication in the *New Zealand Gazette*.

(b) Pursuant to section 20 (1), declares that, pursuant to an agreement to that effect having been entered into, the land described in the Second Schedule to this notice is hereby acquired in connection with a limited access road

(segregation strip) and is vested in the Crown on the date of publication in the *New Zealand Gazette*.

(c) Pursuant to section 52 (1), and to section 88 (2) of the Transit New Zealand Act 1989, declares the land described in the Third Schedule to this notice to be set apart for limited access road, which becomes road, limited access road and State highway and to remain vested in the Crown.

(d) Pursuant to section 52 (1), declares the land described in the Fourth Schedule to this notice to be set apart in connection with a limited access road (segregation strip), and to remain vested in the Crown.

(e) Pursuant to sections 116 and 52 (1), declares the portions of road described in the Fifth and Sixth Schedules to this notice to be stopped and declares that:

(i) The area described in the Fifth Schedule to be set apart in connection with a limited access road (segregation strip), and to remain vested in the Crown.

(f) Declares the land described in the Seventh Schedule to be severance under section 119 (1).

(g) Pursuant to section 20 (1), declares that, pursuant to an agreement to that effect having been entered into, the land described in the Eighth Schedule to this notice is hereby acquired in connection with a limited access road and is vested in the Crown on the date of publication in the *New Zealand Gazette*.

North Auckland Land District

First Schedule

Area m ²	Being
28	Part Lot 14, D.P. 17425; shown marked "B" on S.O. Plan 69130.
381	Part Allotment 232, Town of Pokeno; shown marked "C" on S.O. Plan 69130.
661	Part Lot 13, D.P. 17425; shown marked "D" on S.O. Plan 69130.
6099	Part Allotment 233, Town of Pokeno; shown marked "E" on S.O. Plan 69130.
386	Part Lot 12, D.P. 17425; shown marked "F" on S.O. Plan 69130.
915	Part Lot 11, D.P. 17425; shown marked "G" on S.O. Plan 69130.
2155	Part Lot 8, D.P. 17425; shown marked "H" on S.O. Plan 69130.
36	Section 3, S.O. 64520; shown marked "D1" on S.O. Plan 69130.
127	Section 2, S.O. 64520; shown marked "D2" on S.O. Plan 69130.
110	Part Lot 6, D.P. 17425; shown marked "T" on S.O. Plan 69130.
117	Part Section 1, S.O. 64520; shown marked "N" on S.O. Plan 69130.
108	Part Section 1, S.O. 64520; shown marked "O" on S.O. Plan 69130.
7129	Part Lot 23, D.P. 13817; shown marked "S" on S.O. Plan 69130.
176	Part Lot 7, D.P. 17425; shown marked "I" on S.O. Plan 69131.
614	Part Lot 7, D.P. 17425; shown marked "J" on S.O. Plan 69131.
1531	Part Lot 21, D.P. 13817; shown marked "U" on S.O. Plan 69131.
485	Part Lot 21, D.P. 13817; shown marked "U2" on S.O. Plan 69131.

Second Schedule

Land Acquired in Connection With a Limited Access Road (segregation strip)

Area m ²	Being
1	Part Lot 14, D.P. 17425; shown marked "B1" on S.O. Plan 69130.
1	Part Allotment 232, Town of Pokeno; shown marked "C1" on S.O. Plan 69130.
1	Part Allotment 233, Town of Pokeno; shown marked "E1" on S.O. Plan 69130.
1	Part Lot 11, D.P. 17425; shown marked "G1" on S.O. Plan 69130.
2	Part Lot 8, D.P. 17425; shown marked "H1" on S.O. Plan 69130.
1	Part Lot 6, D.P. 17425; shown marked "T1" on S.O. Plan 69130.
1	Part Lot 23, D.P. 13817; shown marked "S1" on S.O. Plan 69130.
1	Part Section 1, S.O. 64520; shown marked "N1" on S.O. Plan 69130.
1	Part Section 1, S.O. 64520; shown marked "O1" on S.O. Plan 69130.
1	Part Lot 7, D.P. 17425; shown marked "I1" on S.O. Plan 69131.
1	Part Lot 7, D.P. 17425; shown marked "J1" on S.O. Plan 69131.
2	Part Lot 21, D.P. 13817; shown marked "U1" on S.O. Plan 69131.

Third Schedule

Land Set Apart For Limited Access Road

Area m ²	Being
1310	Part Allotment 789, Town of Pokeno; shown marked "A" on S.O. Plan 69130.
38	Part Lot 13, D.P. 17425; shown marked "N2" on S.O. Plan 69130.
100	Part Lot 12, D.P. 17425; shown marked "P" on S.O. Plan 69130.
145	Part Allotment 223, Suburbs of Pokeno; shown marked "Q" on S.O. Plan 69130.
9721	Part Lot 2, D.P. 108235; shown marked "K" on S.O. Plan 69131.
ha	
1.2706	Part Lot 1, D.P. 108235; shown marked "L" on S.O. Plan 69132.

Fourth Schedule

Land Set Apart in Connection With a Limited Access Road (segregation strip)

Area m ²	Being
1	Part Allotment 789, Town of Pokeno; shown marked "A1" on S.O. Plan 69130.
1	Part Lot 12, D.P. 17425; shown marked "P1" on S.O. Plan 69130.
1	Part Allotment 233, Suburbs of Pokeno; shown marked "Q1" on S.O. Plan 69130.
4	Part Lot 2, D.P. 108235; shown marked "K1" on S.O. Plan 69131.
7	Part Lot 1, D.P. 108235; shown marked "L1" on S.O. Plan 69132.

Fifth Schedule*Road Stopped and Set Apart in Connection With a Limited Access Road (segregation strip)*

Area m ²	Adjoining or passing through
1	Part Allotment 232, Town of Pokeno; shown marked "W" on S.O. Plan 69130.
1	Part Lot 11, D.P. 17425; shown marked "W1" on S.O. Plan 69130.
1	Part Lot 8, D.P. 17425; shown marked "W2" on S.O. Plan 69130.
1	Part Allotment 232, Suburbs of Pokeno; shown marked "R1" on S.O. Plan 69130.
1	Part Lot 7, D.P. 17425; shown marked "W3" on S.O. Plan 69131.
1	Part Lot 2, D.P. 108235; shown marked "W4" on S.O. Plan 69131.
4	Part Lot 21, D.P. 13817; shown marked "W5" on S.O. Plan 69131.
1	Part Lot 7, D.P. 17425; shown marked "W6" on S.O. Plan 69131.

Sixth Schedule*Road Stopped*

Area m ²	Adjoining or passing through
506	Part Allotment 232, Town of Pokeno; shown marked "V" on S.O. Plan 69130.
1073	Part Lot 11, D.P. 17425; shown marked "V1" on S.O. Plan 69130.
1347	Part Lot 11, D.P. 17425; shown marked "V2" on S.O. Plan 69130.
3377	Part Allotment 233, Suburbs of Pokeno; shown marked "R" on S.O. Plan 69130.

Seventh Schedule*Severance*

Area m ²	Being
176	Part Allotment 233, Town of Pokeno; shown marked "X" on S.O. Plan 69130.
195	Part Section 789, Town of Pokeno; shown marked "X1" on S.O. Plan 69130.
4388	Part Section 1, S.O. 64520; shown marked "O2" on S.O. Plan 69130.
125	Part Lot 12, D.P. 17425; shown marked "P2" on S.O. Plan 69130.
1130	Part Section 233, Suburbs of Pokeno; shown marked "Q2" on S.O. Plan 69130.
488	Part Lot 23, D.P. 13817; shown marked "S2" on S.O. Plan 69130.
372	Part Lot 6, D.P. 17425; shown marked "T2" on S.O. Plan 69130.
8100	Part Lot 21, D.P. 13817; shown marked "U3" on S.O. Plan 69131.
4378	Part Lot 1, D.P. 108235; shown marked "L2" on S.O. Plan 69132.
277	Part Lot 22, D.P. 13817; shown marked "M" on S.O. Plan 64520.

Eighth Schedule*Land Acquired in Connection With a Limited Access Road*

Area ha	Being
15.6041	Allotments 221, 624, 625, 628, 636, 637, 638, 642, 643, 644, 648, 653, 654, 656, 657, 663, 665, 667, 670, 671, 679, 691, 692, 695, 700, 701, 702, 705, 709, 714, 721, 742, 745, 746 and Parts of Allotments 684, 688, 690 of the Town of Pokeno, Allotments 232, 233, 234, 235, 239, 240, 241, 242, 243, 244, 245, 245A, 247, 248, 249, 250 and Parts of Allotments 231, 246, 254 of the Suburbs of Pokeno and Allotments 140, 143, 144, 145 of the Parish of Maungatawhiri some of the boundaries of the said parcels of land being shown on plans deposited in the Land Registry Office at Auckland, No. 13817 and 17425, being balance of certificate of title 422/126.

Dated at Wellington this 10th day of August 1998.

SARAH CAROLINE BUCHANAN, for Minister of Lands.

(LINZ CPC/1998/417/A)

1CL

ln6077

Road Realignment in Waipa District (Taotaoroa Road)

Pursuant to the Public Works Act 1981, and to a delegation from the Minister of Lands, Sarah Caroline Buchanan, Land Information New Zealand, declares:

(a) Pursuant to section 114, the land described in the First Schedule to this notice, to be road and vested in the Waipa District Council.

(b) Pursuant to sections 116, 117 and 120, the portion of road described in the Second Schedule to this notice, to be stopped and shall be amalgamated with the land in certificate of title, Volume 186, folio 64, subject to memorandum of mortgage B. 380051.2.

South Auckland Land District—Waipa District**First Schedule**

Area m ²	Being
650	Part Lot 6, D.P. 7203; marked "A" on S.O. Plan 58265, lodged in the office of the Chief Surveyor at Hamilton.
450	Part Lot 6, D.P. 7203; marked "B" on S.O. Plan 58265, lodged in the office of the Chief Surveyor at Hamilton.

Second Schedule

Area m ²	Adjoining or passing through
265	Lot 6, D.P. 7203; marked "D" on S.O. Plan 58265, lodged in the office of the Chief Surveyor at Hamilton.

Dated at Wellington this 19th day of August 1998.

SARAH BUCHANAN, for Minister of Lands.

(LINZ CPC/1998/281/Z)

1CL

ln6095

Land Declared to be Road at Ida Valley Omakau Road in the Central Otago District

Pursuant to section 114 of the Public Works Act 1981, and to a delegation from the Minister of Lands, Sarah Caroline Buchanan, Land Information New Zealand, declares the land described in the Schedule hereto, to be road and vested in The Central Otago District Council.

Schedule

Otago Land District—Central Otago District

Area m ²	Being
247	Part Section 71, Block II, Tiger Hill Survey District; marked "A" on S.O. Plan 24630 (part certificate of title 14A/1089).
286	Part Section 71, Block II, Tiger Hill Survey District; marked "B" on S.O. Plan 24630 (part certificate of title 14A/1089).

As shown on the plan above mentioned, lodged in the office of the Chief Surveyor at Dunedin.

Dated at Wellington this 20th day of August 1998.

SARAH BUCHANAN, for Minister of Lands.

(LINZ CPC/1998/415/A)

ICL

ln6098

Land Acquired for a Limited Access Road in Kaipara District—State Highway 1, Kaiwaka

Pursuant to section 20 (1) of the Public Works Act 1981, and to section 88 (2) of the Transit New Zealand Act 1989, and to a delegation from the Minister of Lands, Sarah Caroline Buchanan, Land Information New Zealand, declares that, pursuant to an agreement to that effect having been entered into, the land described in the Schedule to this notice is hereby acquired for limited access road, which becomes road, limited access road and State highway and is vested in the Crown on the date of publication in the *Gazette*.

Schedule

North Auckland Land District

Area m ²	Being
325	Part Lot 1, D.P. 179675; marked "F" on S.O. Plan 69124.
43	Part Allotment 371, Parish of Kaiwaka; marked "G" on S.O. Plan 69124.

Dated at Wellington this 18th day of August 1998.

SARAH BUCHANAN, for the Minister of Lands.

(CPC/1998/500/A)

ICL

ln6151

Road Realignment in the Mackenzie District (Opihi River)

Pursuant to the Public Works Act 1981, and to a delegation from the Minister of Lands, Sarah Caroline Buchanan, Land Information New Zealand:

(a) Pursuant to section 20, declares that an agreement to that effect having been entered into, the land described in the First Schedule is hereby acquired for road, which pursuant to section 60 (2) of the Transit New Zealand Act 1989, shall form part of State Highway No. 8 and shall vest in the Crown on the date of publication in the *New Zealand Gazette*.

(b) Pursuant to section 114, declares the land described

in the Second Schedule to be road, which pursuant to section 60 (2) of the Transit New Zealand Act 1989, shall form part of State Highway No. 8 and shall remain vested in the Crown.

(c) Pursuant to sections 116, 117 and 120 (3), declares the road described in the Third Schedule to be stopped and further declares that the stopped road shall be amalgamated with the land in certificate of title 33B/620, subject to mortgage 935078/5 (Canterbury Registry).

(d) Pursuant to section 119, declares the land described in the Fourth Schedule to be taken for severance and amalgamated with the land in certificate of title 33B/620, subject to mortgage 935078/5 (Canterbury Registry).

First Schedule

Canterbury Land District

3490 square metres, more or less, being part Rural Section 36085; shown as "A" on plan.

Second Schedule

Canterbury Land District

7058 square metres, more or less, being Crown land; shown as "B" on plan.

Third Schedule

Canterbury Land District

1.1088 hectares, more or less, being legal road adjoining part Rural Section 36085 and Crown land; shown as "D" on plan.

Fourth Schedule

Canterbury Land District

630 square metres, more or less, being Crown land; shown as "C" on plan.

As shown as above on S.O. 16700, lodged in the office of the Chief Surveyor at Christchurch.

Dated at Wellington this 17th day of August 1998.

SARAH BUCHANAN, for Minister of Lands.

(LINZ Chch. 40/72/8/15/17, CPC/1998/572)

ICL

ln6153

Land Acquired for Limited Access Road and for Use in Connection With a Road and Road Stopped—State Highway No. 6, Richmond

Pursuant to the Public Works Act 1981, and to a delegation from the Minister of Lands, Sarah Caroline Buchanan, Land Information New Zealand:

(a) Pursuant to section 20, declares that, an agreement to that effect having been entered into, the land described in the First Schedule is hereby acquired for limited access road, which pursuant to section 88 (2) of the Transit New Zealand Act 1989, has become road, limited access road and State highway and shall vest in the Crown on the date of publication in the *New Zealand Gazette*.

(b) Pursuant to section 20, declares that, an agreement to that effect having been entered into, the land described in the Second Schedule is acquired for use in connection with a road and shall vest in the Crown on the date of publication in the *New Zealand Gazette*.

(c) Pursuant to sections 116, 117 and 120 (3), declares the road described in the Third Schedule to be stopped and further declares that the stopped road shall be amalgamated with the land in certificate of title 4C/271 (Nelson Registry) subject to drainage rights created by conveyance 35187 (37D32).

First Schedule**Nelson Land District—Nelson City**

Area m ²	Being
7527	Part Lot 2, D.P. 3380; shown as "B" on plan.
45	Part Lot 1, D.P. 8040; shown as "C" on plan.
34	Part Lot 2, D.P. 3380; shown as "D" on plan.
295	Part Lot 1, D.P. 10236; shown as "F" on plan.
697	Part Lot 2, D.P. 3342; shown as "H" on plan.
ha	
1.4367	Part Lot 2, D.P. 3342; shown as "E" on plan.

Second Schedule**Nelson Land District—Nelson City**

Area m ²	Being
5886	Part Lot 2, D.P. 3380; shown as "A" on plan.
ha	
2.4799	Part Lot 2, D.P. 3342; shown as "I" on plan.

Third Schedule**Nelson Land District—Nelson City**

Area m ²	Adjoining
112	Part Lot 2, D.P. 3380; shown as "K" on plan.

As shown as above mentioned on S.O. 15525, lodged in the office of the Chief Surveyor at Nelson.

Dated at Wellington this 17th day of August 1998.

SARAH BUCHANAN, for Minister of Lands.

(LINZ Nn 72/6/11/2/0/101, CPC/1998/573) ICL

ln6154

Land Declared to be Limited Access Road — State Highway No. 6, Richmond

Pursuant to section 114 of the Public Works Act 1981, and to a delegation from the Minister of Lands, Sarah Caroline Buchanan, Land Information New Zealand, declares the land described in the Schedule hereto, to be road and vested in the Crown on the date of publication hereof in the *New Zealand Gazette*.

Schedule**Nelson Land District—Nelson City**

6584 square metres, more or less, being Crown land; shown as "G" on S.O. Plan 15525, lodged in the office of the Chief Surveyor at Nelson.

Dated at Wellington this 17th day of August 1998.

SARAH BUCHANAN, for Minister of Lands.

(LINZ Nn. 72/6/11/2/0/101, CPC/1998/573) ICL

ln6155

Land Acquired for Limited Access Road — State Highway No. 6, Richmond

Pursuant to section 20 of the Public Works Act 1981, and to a delegation from the Minister of Lands, Sarah Caroline Buchanan, Land Information New Zealand, declares that, an agreement to that effect having been entered into, the land described in the Schedule is acquired for limited access road which, pursuant to section 88 (2) of the Transit New Zealand Act 1989, has become road, limited access road and State Highway and shall vest in the Crown on the date of publication in the *New Zealand Gazette*.

Schedule**Nelson Land District—Tasman District**

811 square metres, more or less, being part Lot 1, D.P. 10599; shown as "J" on S.O. Plan 15525, lodged in the office of the Chief Surveyor at Nelson.

Dated at Wellington this 17th day of August 1998.

SARAH BUCHANAN, for Minister of Lands.

(LINZ Nn. 72/6/11/2/0/101, CPC/1998/573) ICL

ln6156

Land Acquired for Road Diversion, Lincoln Road, Christchurch City

Pursuant to section 20 (1) of the Public Works Act 1981, and to a delegation from the Minister of Lands, Sarah Caroline Buchanan, Land Information New Zealand, declares that, pursuant to an agreement to that effect having been entered into, the land described in the Schedule to this notice is hereby acquired for road diversion together with the rights as set out in the Schedule, and is vested in The Christchurch City Council on the date of publication of this notice in the *New Zealand Gazette*.

Schedule**Canterbury Land District**

Area m ²	Being
1011	Lot 3, D.P. 479 (all certificate of title 27F/948).
607	Part Lots 2 and 3, D.P. 2835 (all certificate of title 353/214).
703	Lot 3, D.P. 22425, together with the appurtenant right of way contained in transfer 612999 (all certificate of title 33B/291).
627	Lot 2, D.P. 22425, together with the appurtenant right of way contained in transfer 612999 (all certificate of title 33B/290).

Dated at Wellington this 18th day of August 1998.

SARAH BUCHANAN, for Minister of Lands.

(CPC/98/375/A, 376/A, 377/A) ICL

ln6182

Land in Whakatane District Declared to be Crown Land

Pursuant to section 42 of the Public Works Act 1981, and to a delegation from the Minister of Lands, Sarah Caroline Buchanan, Land Information New Zealand, declares the land described in the Schedule hereto, to be Crown land, subject to the Land Act 1948.

Schedule**South Auckland Land District**

Area ha	Being
18.9960	Part Matahina A10; marked "A" on S.O. Plan 60909.
29.2900	Part Tuararangaia 382 and closed road; marked "B" on S.O. Plan 60909.

S.O. 60909 is lodged in the office of the Chief Surveyor at Hamilton.

Dated at Wellington this 25th day of August 1998.

SARAH CAROLINE BUCHANAN, for Minister of Lands.

(LINZ CPC/1998/623) ICL

ln6183

Land in Whakatane District Declared to be Crown Land

Pursuant to section 42 of the Public Works Act 1981, and to a delegation from the Minister of Lands, Sarah Caroline Buchanan, Land Information New Zealand, declares the land described in the Schedule hereto, to be Crown land, subject to the Land Act 1948.

Schedule

South Auckland Land District

Area ha	Being
5.4000	Part Section 3, Block III, Rangitaiki Lower Survey District; coloured yellow on S.O. Plan 43438.
5.9362	Part Section 3, Block III, Rangitaiki Lower Survey District; coloured yellow on S.O. Plan 43439.
m ²	
4163	Section 9, Block III, Rangitaiki Lower Survey District; coloured sepia on S.O. Plan 43439.
1527	Part Section 3, Block III, Rangitaiki Lower Survey District; coloured yellow on S.O. Plan 43439.

As shown on the plans coloured as above mentioned and lodged in the office of the Chief Surveyor at Hamilton.

Dated at Wellington this 25th day of August 1998.

SARAH CAROLINE BUCHANAN, for Minister of Lands.

(LINZ CPC/1998/623)

icL

ln6184

Land Acquired for Road, Road Stopped and Amalgamated, Wallaceville Road, Upper Hutt

Pursuant to Part III of the Public Works Act 1981, and to a delegation from the Minister of Lands, R. A. Jolly, Land Information New Zealand:

(a) Pursuant to section 114 (1), declares the land described in the First Schedule to this notice to be road vested in The Upper Hutt City Council on the date of publication hereof in the *New Zealand Gazette*.

(b) Pursuant to sections 116 (1), 117 and 120 (3), declares the portions of road described in the Second Schedule to be stopped and further declares:

(i) The areas marked "D" and "I" to be amalgamated with the land in certificate of title 348/251.

First Schedule

Wellington Land District

Area m ²	Being
332	Part Section 150, Hutt District, Block I, Rimutuka Survey District; marked "F" on S.O. Plan 37045.
71	Part Section 150, Hutt District, Block I, Rimutuka Survey District; marked "K" on S.O. Plan 37046.

Second Schedule

Area m ²	Adjoining or passing through
25	Part Section 150, Hutt District, Block I, Rimutuka Survey District; marked "D" on S.O. Plan 37045.

Area m ²	Adjoining or passing through
------------------------	------------------------------

124 Part Section 150, Hutt District, Block I, Rimutuka Survey District; marked "I" on S.O. Plan 37046.

Dated at Wellington this 19th day of August 1998.

RONALD ALISTAIR JOLLY, for Minister of Lands.

(LINZ/CPC/378/A)

icL

ln6181

Road Realignment in Waipa District (Paterangi Road)

Pursuant to the Public Works Act 1981, and to a delegation from the Minister of Lands, Ronald Alistair Jolly, Land Information New Zealand, declares:

(a) Pursuant to section 114, the land described in the First Schedule to this notice, to be road and vested in The Waipa District Council.

(b) Pursuant to sections 116, 117 and 120, the portion of road described in the Second Schedule to this notice, to be stopped and amalgamated with the land in certificate of title No. 23A/1215, subject to memorandum of mortgage B. 227733.3.

(c) Pursuant to sections 116, 117 and 120, the portions of road described in the Third Schedule to this notice, to be stopped and amalgamated with the land in certificate of title No. 24C/493.

(d) Pursuant to sections 116, 117 and 120, the portion of road described in the Fourth Schedule to this notice, to be stopped and amalgamated with the land in certificate of title No. 24C/494.

(e) The land described in the Fifth Schedule to this notice, to be taken under section 119 and shall be amalgamated with the land in certificate of title No. 24C/493.

(f) The land described in the Sixth Schedule to this notice, to be taken under section 119 and shall be amalgamated with the land in certificate of title No. 23A/1215, subject to memorandum of mortgage B. 227733.3.

South Auckland Land District—Waipa District

First Schedule

Area m ²	Being
4788	Part Lot 1, D.P. S. 81092, formerly being part Lot 25, D.P. 20888; marked "B" on S.O. Plan 60796.
3493	Part Lot 24, D.P. 20888; marked "C" on S.O. Plan 60796.
592	Part Lot 23, D.P. 20888; marked "D" on S.O. Plan 60796.

Second Schedule

Area m ²	Adjoining or passing through
3838	Lot 4, D.P. S. 20551; marked "J" on S.O. Plan 60796.

Third Schedule

Area m ²	Adjoining or passing through
2337	Lot 1, D.P. S. 25616; marked "K" on S.O. Plan 60796.
1883	Lot 2, D.P. S. 25616; marked "L" on S.O. Plan 60796.

Fourth Schedule

Area m ²	Adjoining or passing through
96	Lot 2, D.P. S. 25616; marked "M" on S.O. Plan 60796.

Fifth Schedule

Area m ²	Being
779	Part Lot 24, D.P. S. 20888; marked "E" on S.O. Plan 60796.
764	Part Lot 24, D.P. S. 20888; marked "F" on S.O. Plan 60796.
3618	Part Lot 1, D.P. S. 81092; formerly being part Lot 25, D.P. 20888; marked "G" on S.O. Plan 60796.

Sixth Schedule

Area m ²	Being
4207	Part Lot 1, D.P. S. 81092; formerly being part Lot 25, D.P. 20888; marked "H" on S.O. Plan 60796.

Dated at Wellington this 18th day of August 1998.

Signed by:

RONALD ALISTAIR JOLLY, for the Minister of Lands.

(LINZ CPC/1998/391)

ICL

In6043

Land to be Declared Road in Auckland City

Pursuant to section 114 of the Public Works Act 1981, the Minister of Lands declares the land described in the Schedule to be road, which shall remain vested in The Auckland City Council on the date of publication in the *New Zealand Gazette*.

Schedule**North Auckland Land District**

Area m ²	Being
44	Part Lot 1, D.P. 8789; marked "A" on plan.
38	Part Lot 29, D.P. 302; marked "B" on plan.
40	Part Lot 130, D.P. 4347; marked "C" on plan.
46	Part Lot 2, D.P. 50148; marked "D" on plan.

As shown as above mentioned on S.O. Plan 69207, lodged in the office of the Chief Surveyor in Auckland.

Dated at Auckland this 12th day of August 1998.

R. J. SUTHLERLAND, for Minister of Lands.

(LINZ AK RO 15-84-0-SO 69207)

ICL

In6074

Land to be Declared Road in Auckland City

Pursuant to section 20 of the Public Works Act 1981, the Minister of Lands declares that an agreement to that effect

having been entered into, the land described in the Schedule is acquired for road and shall vest in the Auckland City Council on the date of publication in the *New Zealand Gazette*.

Schedule**North Auckland Land District**

5 square metres, being part Lot 1, D.P. 67498; marked "CC" on S.O. Plan 68138, lodged in the office of the Chief Surveyor at Auckland.

Dated at Auckland this 12th day of August 1998.

R. J. SUTHLERLAND, for Minister of Lands.

(LINZ AK RO 15-84-0-SO 68138)

ICL

In6075

Land to be Acquired for Road in Auckland City

Pursuant to section 20 of the Public Works Act 1981, the Minister of Lands declares that an agreement to that effect having been entered into, the land described in the Schedule is acquired for road and shall vest in The Auckland City Council on the date of publication in the *New Zealand Gazette*.

Schedule**North Auckland Land District**

25 square metres, being part Lot 17, D.P. 51781; marked "A" on S.O. Plan 69206, lodged in the office of the Chief Surveyor at Auckland.

Dated at Auckland this 12th day of August 1998.

R. J. SUTHLERLAND, for Minister of Lands.

(LINZ Ak. R.O. 15-84-0-SO 69206)

ICL

In6076

Land Acquired for Better Utilisation (Access Way) in Waikato District

Pursuant to section 20 (1) of the Public Works Act 1981, and to a delegation from the Minister of Lands, R. J. Sutherland, Land Information New Zealand, declares that, pursuant to an agreement to that effect having been entered into, the land described in the Schedule to this notice is hereby acquired for better utilisation (access way) and shall vest in The Waikato District Council on the date of publication hereof in the *New Zealand Gazette*.

Schedule**South Auckland Land District—Waikato District**

37 square metres being part Allotment 19, Town of Raglan; marked "A" on S.O. Plan 60748.

Dated at Auckland this 10th day of August 1998.

R. J. SUTHERLAND, for Minister of Lands.

(LINZ CPC 98402A)

ICL

In6148

Land Acquired for Granting as Compensation in Waikato District

Pursuant to sections 20 (1) and 21 of the Public Works Act 1981, and to a delegation from the Minister of Lands, R. J. Sutherland, Land Information New Zealand, declares that, pursuant to an agreement to that effect having been entered into, the land described in the Schedule to this notice is hereby acquired for granting as compensation and shall vest in The Waikato District Council on the date of publication of this notice in the *New Zealand Gazette*.

Schedule**South Auckland Land District—Waikato District**

1 square metres being part Lot 7, D.P. S. 41049; as shown marked "C" on S.O. Plan 60748, lodged in the office of the Chief Surveyor at Hamilton.

Dated at Auckland this 10th day of August 1998.

R. J. SUTHERLAND, for Minister of Lands.

(LINZ CPC 98402A)

1CL

ln6149

Land Set Apart for Granting as Compensation in Waikato District

Pursuant to section 52 of the Public Works Act 1981, and to a delegation from the Minister of Lands, R. J. Sutherland, Land Information New Zealand, declares the land described in the Schedule to this notice, to be set apart for granting as compensation and remain vested in The Waikato District Council.

Schedule**South Auckland Land District—Waikato District**

24 square metres being part Lot 7, D.P. S. 41049; marked "B" on S.O. Plan 60748.

Dated at Auckland this 10th day of August 1998.

R. J. SUTHERLAND, for Minister of Lands.

(LINZ CPC 98402A)

1CL

ln6150

Land Held for Education Purposes Set Apart For Special School in Papakura District

Pursuant to section 52 of the Public Works Act 1981, and to a delegation from the Minister of Lands, R. J. Sutherland, Land Information New Zealand, declares the land described in the Schedule to be set apart for a special school.

Schedule**North Auckland Land District**

759 square metres, being Lot 139, Deposited Plan 47965 and being parts Allotment E.11, Parish of Opaheke. Subject to fencing covenant in transfer 683801 and building line restriction in K. 77336. All certificate of title 54D/788.

Dated at Auckland this 19th day of August 1998.

R. J. SUTHERLAND, for Minister of Lands.

(LINZ File: Ak. R.O. 23/384/0)

1CL

ln6094

Declaration Acquiring Easements for Irrigation Purposes (Maungatapere Irrigation Scheme) Over Land in the Whangarei District

Pursuant to section 28 of the Public Works Act 1981, and to a delegation from the Minister of Lands, R. J. Sutherland, Land Information New Zealand, declares that, agreements to that effect having been entered into, rights to convey water over the land described in the First Schedule hereto, containing the rights and powers as contained in the Second Schedule hereto, are acquired for irrigation purposes for a term expiring on the 31st day of December 2050 and shall vest in the Crown on the date of publication of this notice in the *New Zealand Gazette*.

First Schedule**North Auckland Land District**

Area m ²	Being
2490	Part Lot 1, D.P. 181774; marked "B" on plan.
866	Part Lot 4, D.P. 138357; marked "C" on plan.
1165	Part Lot 3, D.P. 138357; marked "D" on plan.
1172	Part Lot 4, D.P. 141434; marked "E" on plan.
529	Part Lot 5, D.P. 141434; marked "F" on plan.

Shown marked as above mentioned on S.O. Plan 67717, lodged in the office of the Chief Surveyor at Auckland.

Second Schedule

The rights and powers contained in the Second and Fourth paragraphs of the Seventh Schedule of the Land Transfer Act 1952, as modified by the additional terms and conditions described in the agreements between Her Majesty the Queen and:

Owner	Dated	Certificate of Title
Philip Murray Hawkins and Juliana Maria Hawkins	24 December 1993	89C/593 (now 105D/976)
Sholto William McCardle and Leslie Fiona McCardle	24 December 1993	81D/938
Christine Findley	24 December 1993	89C/965
Alasdair Campbell McLaughlan and Elizabeth Jean McLaughlan	6 September 1994	83D/820
Peter Stanley Pascoe and Fiona Jane Pascoe	14 March 1994	83D/821

copies of which can be sighted on the LINZ file mentioned below, and copies of which will be registered against the said certificates of title along with this notice.

Dated at Wellington this 17th day of August 1998.

R. J. SUTHERLAND, for Minister of Lands.

(LINZ CPC/1998/465)

ln6035

Regulation Summary**Notice Under the Acts and Regulations Publication Act 1989**

Pursuant to the Acts and Regulations Publication Act 1989, notice is hereby given of the making of regulations as under:

<i>Authority for Enactment</i>	<i>Title or Subject-matter</i>	<i>Serial Number</i>	<i>Date of Enactment</i>	<i>Price Code</i>	<i>Postage and Packaging</i>
Securities Act 1978	Securities Act (Govett Oriental Investment Trust PLC) Exemption Notice 1998	1998/238	26/8/98	3-BX	\$2.10
Health and Disability Services Amendment Act 1998	Health and Disability Services Amendment Act 1998 Commencement Order 1998	1998/239	24/8/98	2-A	\$1.60
Fisheries Act 1996	Fisheries (South Tasman Rise Orange Roughy Fishery) Regulations 1998	1998/240	24/8/98	4-BX	\$2.10
Social Security Act 1964	Social Security (Invalid's Benefit) Regulations 1998	1998/241	24/8/98	2-A	\$1.60
Social Welfare (Transitional Provisions) Act 1990	Social Welfare (Reciprocity with Australia) Amendment Order 1998	1998/242	24/8/98	5-BY	\$2.30
Extradition Act 1965	Extradition (Hong Kong Special Administrative Region of the People's Republic of China) Order 1998	1998/243	24/8/98	13-CX	\$3.60
Residential Tenancies Act 1986	Residential Tenancies (Fees) Regulations 1998	1998/244	24/8/98	2-A	\$1.60
Income Tax Act 1994	Income Tax (Fringe Benefit Tax, Interest on Loans) Amendment Regulations (No. 3) 1998	1998/245	24/8/98	2-A	\$1.60
Securities Act 1978	Securities Act (Industry Retirement & Insurance Services Limited) Exemption Notice 1998	1998/246	25/8/98	2-A	\$1.60

Postage and Packaging Charge: Mail Orders

If two or more copies ordered, the remittance should cover the *cash price* and the *maximum charge* for the *total value of purchases* as follows:

<i>Total Value of Purchases</i>	<i>Maximum Charge</i>
\$	\$
\$12.00 and less	1.50
\$12.01 and greater	3.25

Copies can be bought or ordered by mail from Legislation Services, P.O. Box 12-418, Wellington. Please quote title and serial numbers. Prices for quantities supplied on application. Copies are also available over the counter at the following locations:

Bennetts Bookshop Limited: Level One, Whitcoulls Corner Store, Queen Street (P.O. Box 5513, Wellesley Street), Auckland; 111 Cashel Street (Private Bag), Christchurch 1; located in Whitcoulls, 143 George Street (P.O. Box 1104), Dunedin; 38-42 Broadway Avenue (P.O. Box 138), Palmerston North; Massey University, Palmerston North; located in Whitcoulls, Centreplace, Bryce Street (P.O. Box 928), Hamilton; Bowen House, Lambton Quay (P.O. Box 5334), Wellington.

rs6174

General

Land Transport Safety Authority

Traffic Regulations 1976

General Approval—Overdimension Vehicles and Loads

Pursuant to regulation 49 of the Traffic Regulations 1976, and by way of a subdelegation from the Director of Land Transport Safety dated 18 December 1996, I, Wayne Robert Pettersson, Senior Engineer, hereby approve the operation of the vehicle types and loads described in this notice contrary to the provisions of regulations 48B to 48D.

Vehicles and loads which exceed the dimension limits set out in the Traffic Regulations 1976 and which are not described in this notice or any other notice cannot be operated unless a specific approval has been issued to that vehicle or load under regulation 49A.

This notice comes into effect on the 1st day of September 1998.

Definitions

“Articulated lowbed trailer” means a gooseneck semi-trailer with the loading area of the semi-trailer a maximum of 1.1 metres off the ground.

“Indivisible load” means a load which cannot reasonably (without disproportionate effort, expense or risk of damage to the load) be divided into two or more sections for road transport, and cannot be carried on a vehicle within the dimension limits set out in the Traffic Regulations 1976. ISO containers and similar types of containers with closed tops are excluded from this definition.

“Load divider trailer” means a type of short semi-trailer designed to load share but not to directly carry any goods, and with one or more axles, equipped with a king pin, a fifth wheel and other parts necessary for attaching it to the rear end of a prime mover and the front portion of a second gooseneck trailer.

“Trombone articulated trailer” means an extendible semi-trailer whose overall length can be increased for the purpose of carrying indivisible loads.

Operating Conditions

The vehicle types and loads described in this notice must be operated in compliance with the requirements set out in the document “Overdimension Vehicles and Loads: A Guideline to Operating Requirements” dated August 1998 produced by the Land Transport Safety Authority.

Approval for Loads

An indivisible load up to the dimension limits set out below may be transported on a road.

Width and Forward Distance – 4.3 metres wide at 10.8 metres forward distance reducing to 2.5 metres wide at 13.0 metres forward distance in accordance with figure one.

Overall Length – 25.0 metres

Overall Height – 4.8 metres

Front Overhang – 5.0 metres

Rear Overhang – the lesser of 5.0 metres (6.0 metres for loads on articulated trailers) or 50% of the load length

Figure One—Width and Forward Distance Limits of Loads covered by this Notice

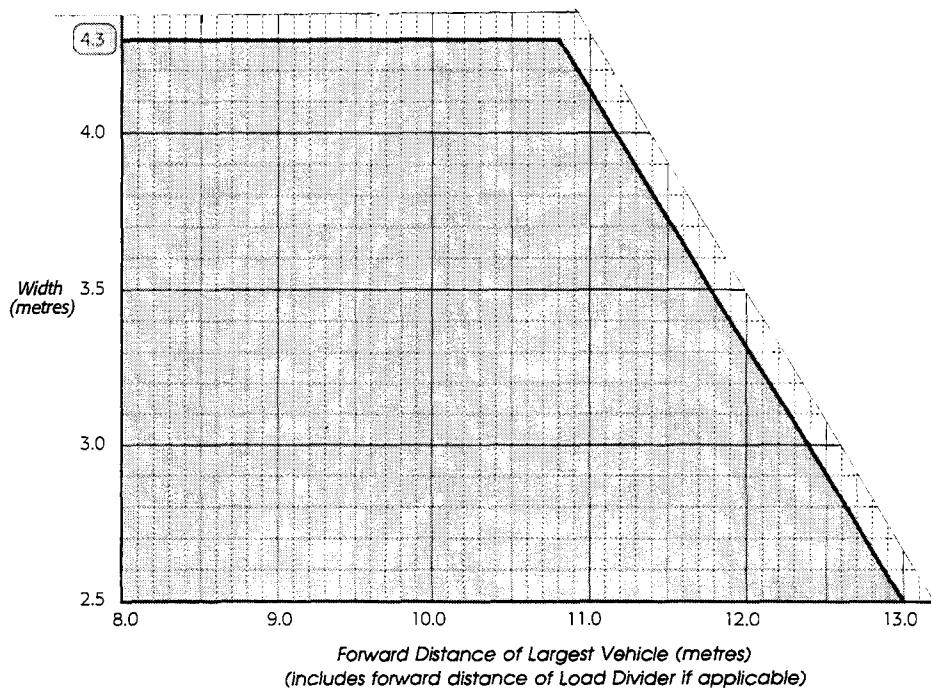

General Approval for Vehicles

This approval relates only to vehicles which are principally designed for the carriage of overdimension and overweight loads and includes:

Articulated lowbed and load divider trailers;

Trombone and fixed length articulated and full trailers used for house haulage;

Trombone articulated trailers used for general divisible goods in the closed position and indivisible goods in the open position;

Multi-axle full trailers; and

Other vehicles approved by the Director of Land Transport Safety

Vehicles of the above types which exceed the dimension limits set out in the Traffic Regulations 1976, and which are within the dimension limits set out below may operate on a road.

Width and Forward Distance—3.1 metres wide at 10.5 metres forward distance reducing to 2.5 metres wide at 11.0 metres forward distance in accordance with figure two.

Rear Overhang—	5.0 metres
Front Overhang (Distance ahead of front of driver's seat)—	3.0 metres
Overall Length—	25.0 metres
Height	4.25 metres

These limits apply to a vehicle in its normal travel mode when not carrying a load. Trombone trailers may be extended to different open positions (longer forward distances) in order to safely carry an indivisible load within the dimension limits permitted by this notice.

If the combination includes a load divider with a forward distance greater than 3.5 metres, the forward distance for overdimension purposes shall be calculated by adding the forward distance of the load divider and the forward distance of the trailer and subtracting 3.5 metres. This calculated forward distance can then be checked to determine if the combination falls within the limits of this notice.

Figure Two—Width and Forward Distance Limits

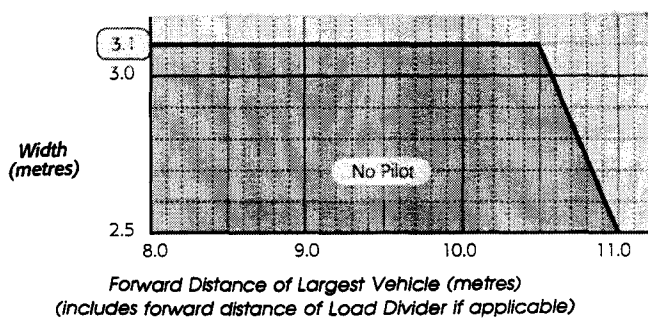

Signed at Wellington this 19th day of August 1998.

W. R. PETTERSSON, Senior Engineer, Safer Roads.

gn6086

General Approval—Overdimension Mobile Cranes

Pursuant to Regulation 49 of the Traffic Regulations 1976, and by way of a subdelegation from the Director of Land Transport Safety dated 18 December 1996, I, Wayne Robert Pettersson, Senior Engineer, hereby approve the operation of the vehicle types described in this notice contrary to the provisions of regulations 48B to 48D.

Mobile cranes which exceed the dimension limits in the Second and Third Schedules cannot operate unless a specific approval has been issued to that vehicle under regulation 49A.

This notice comes into effect on the 1st day of September 1998.

First Schedule

Types of Vehicles

Category 1 Mobile Cranes—Mobile cranes not exceeding the dimension limits described in the Second Schedule.

Category 2 Mobile Cranes—Mobile cranes exceeding the dimension limits described in the Second Schedule but not exceeding the dimension limits described in the Third Schedule.

Definitions

In this schedule—

“Mobile crane” means a non-load carrying self-propelled vehicle designed for lifting heavy objects by way of a boom with lifting gear.

Second Schedule

Dimension limits

Dimension limits of a Category 1 Mobile Crane, as shown in Diagram 1.

Overall width—	2.5 metres
Rear overhang—	4.0 metres
Front overhang (distance ahead of front of driver's seat)—	3.0 metres
Distance from rear of crane to front of crane (excluding boom)—	11.0 metres

Forward distance of crane carrier (excluding boom)—

8.5 metres

Height—

4.25 metres

Diagram 1

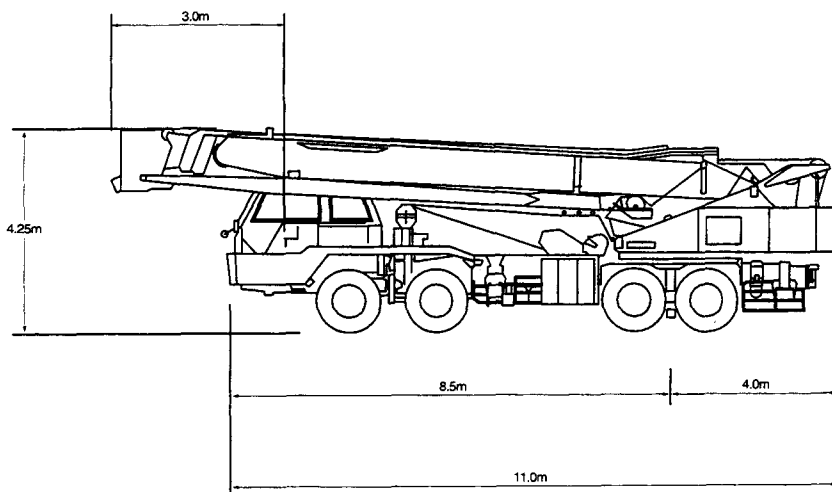

Third Schedule

Dimension limits of a Category 2 Mobile Crane, as shown in Diagram 2.

Overall width— 3.1 metres

Forward distance of crane carrier (excluding boom)— 10.5 metres

Rear overhang— 5.0 metres for mobile cranes with forward facing booms

7.0 metres for mobile cranes with rearward facing booms supported on a trailer. Rear overhang measured from the rear axis of the trailer.

Front Overhang (distance ahead of front of driver's seat)—

3.0 metres for mobile cranes with rearward facing booms

5.0 metres for mobile cranes with forward facing booms

Overall Length— 19.0 metres for mobile cranes not towing a trailer

20.0 metres for mobile cranes with forward facing booms towing a trailer carrying counterweights

25.0 metres for mobile cranes towing a trailer supporting a rearward facing boom and carrying counterweights

Diagram 2

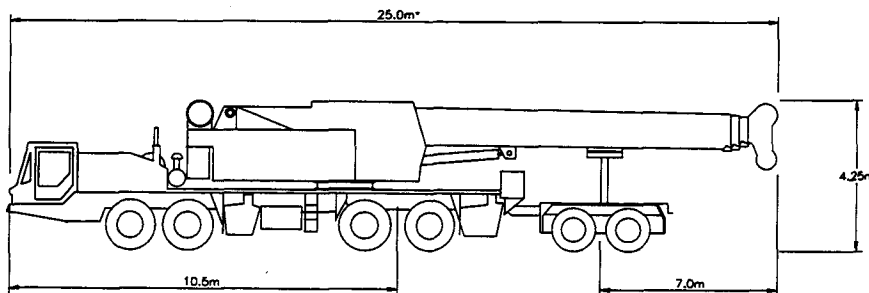

* If the boom is facing forward and a counterweight trailer is being towed the overall length must not exceed 20.0 metres

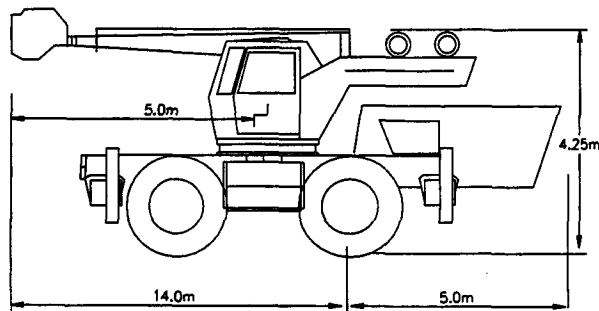
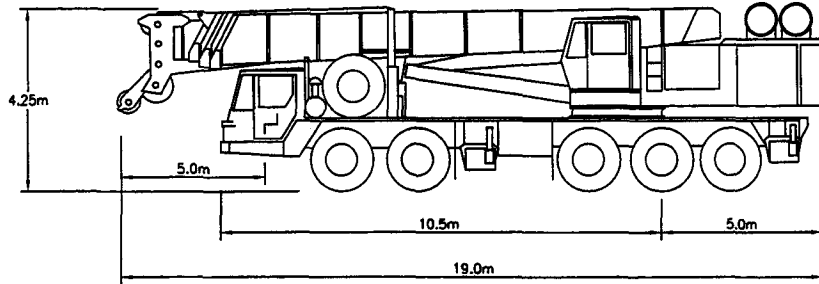

Fourth Schedule

Operating Conditions

The mobile cranes described in this notice must be operated in compliance with the requirements set out in the document "Overdimension Mobile Cranes: A Guideline to Operating Requirements" dated August 1998 produced by the Land Transport Safety Authority.

Signed at Wellington this 19th day of August 1998.

W. R. PETTERSSON, Senior Engineer, Safer Roads.

gn6087

General Approval—Special Overdimension Vehicles

Pursuant to regulation 49 of the Traffic Regulations 1976, and by way of a subdelegation from the Director of Land Transport Safety dated 18 December 1996, I, Wayne Robert Pettersson, Senior Engineer, hereby approve the operation of the vehicle types described in this notice contrary to the provisions of regulations 48B to 48D subject to the operating conditions specified in the relevant documents in the Second Schedule

Vehicles of the types described in the First Schedule and which exceed the dimension limits described in this schedule cannot operate unless a Specific Approval has been issued to that vehicle under regulation 49A.

This notice comes into effect on the 1st day of September 1998. However the period between 1 September 1998 and 1 August 1999 shall be deemed to be a transitional period in which any existing overdimension exemption relating to any of these vehicle types remains in force.

First Schedule

Definitions

In this schedule—

The term "SOV" followed by a specific number relates to a document in the Second Schedule specifying the operating requirements for a particular type of special overdimension vehicle.

Types of vehicles and excess dimension limits permitted

(SOV1) Self-propelled machines designed principally for road maintenance or construction, including excavators, front-end loaders and road graders (but excluding motor scrapers).

Front overhang (distance ahead of front of driver's seat)—6.0 metres

Width—3.1 metres

(SOV2) Motor-Scrapers

Width—3.7 metres

(SOV3) Forklifts (does not include tractors, trucks or multi-purpose vehicles fitted with forks)

Front overhang (distance ahead of front of driver's seat)—6.0 metres

(SOV4) Rigid trucks with a gross vehicle mass exceeding 3500 kg and fitted with a snow plough blade

Front overhang (distance ahead of front of driver's seat)—4.5 metres

Width—3.1 metres

(SOV5) Verge mowers and hedge trimmers on regulation sized vehicles

Front overhang (distance ahead of front of driver's seat)—4.5 metres

Width—3.1 metres

(SOV6) Concrete pumps, personnel lifting buckets and aircraft fertiliser loaders on regulation sized vehicles

Rear overhang—the lesser of 85% of the wheelbase or 5.0 metres

(SOV7) Aggregate chip spreaders on regulation sized vehicles

Width—3.1 metres

(SOV8) Semi-trailers and full trailers fitted with road metal crushers, screening plants or log haulers. Trailers fitted with road metal conveyors.

Semi-trailers and full trailers fitted with road metal crushers, screening plants or log haulers.

Width—3.1 metres

Overall length of combination—22.0 metres

Forward distance—11.0 metres at a width of 2.5 metres reducing uniformly to 10.5 metres at a width of 3.1 metres

Rear overhang—5.0 metres

Trailers fitted with road metal conveyors

Rear overhang—6.0 metres

(SOV9) Drilling Rigs fitted to regulation sized vehicles

Rear overhang—the lesser of 85% of the wheelbase or 5.0 metres

Front overhang—5.0 metres

(SOV10) Fertiliser spreaders

Width—3.1 metres

Rear overhang—the lesser of 65% of the wheelbase or 3.2 metres for trucks under 9.5 metres in length or the lesser of 65% of the wheelbase or 3.7 metres for trucks at least 9.5 metres in length

Second Schedule

Operating conditions

The special overdimension vehicles described in this notice must be operated in compliance with the requirements set out in the corresponding documents SOV1 to SOV10 (inclusive) produced by the Land Transport Safety Authority.

Signed at Wellington this 19th day of August 1998.

W. R. PETTERSSON, Senior Engineer, Safer Roads.

gn6088

General Approval—Special Overdimension Loads

Pursuant to Regulation 49 of the Traffic Regulations 1976, and by way of a subdelegation from the Director of Land Transport Safety dated 18 December 1996, I, Wayne Robert Pettersson, Senior Engineer, hereby approve the operation of the vehicle types and loads described in this notice contrary to the provisions of regulations 48B to 48D subject to compliance with the operating conditions specified in the relevant documents in the Second Schedule.

Vehicles and loads of the types described in the First Schedule and which exceed the dimension limits described in this schedule cannot operate unless a specific approval has been issued to that vehicle and load under regulation 49A.

This notice comes into effect on the 1st day of September 1998. However the period between 1 September 1998 and 1 August 1999 shall be deemed to be a transitional period in which any existing overdimension exemption relating to any of these load types remains in force.

First Schedule

Definitions

In this schedule—

The term "SL" followed by a specific number relates to a document in the Second Schedule specifying the operating requirements for a particular type of special overdimension load.

Types of Vehicles and Loads and excessive dimensions permitted

(SL1) Baled hay or wool carried on a regulation sized heavy motor vehicle

Width—2.7 metres and no more than 1.35 metres either side of the centreline of the vehicle

(SL2) Concrete pipes with a diameter of 0.4 metres or more loaded transversely across the deck on a regulation sized vehicle

Width—2.7 metres and no more than 1.35 metres either side of the centreline of the vehicle

(SL3) Regulation dimension heavy motor vehicles carrying steel for transmission towers, gin poles, telegraph poles or power poles, ladders for work on such poles, or fitted with sheer legs to aid the erection of such poles, where these items are the only ones exceeding the regulation dimensions

Width—2.75 metres and no more than 1.25 metres to the right of the centreline of the vehicle

Rear overhang—4.5 metres except sheer legs

—6.5 metres for sheer legs provided that they are reduced to the minimum practicable overhang travelling from job to job and rise to 3.7 metres above the ground when travelling.

Overall length of a rigid vehicle—11.6 metres when carrying long power poles

(SL4) Rowing skiffs on regulation sized vehicles or trailers

On motor vehicles

Front overhang—4.5 metres

Rear overhang—the lesser of 6.0 metres or the forward distance of the vehicle

On trailers

Rear overhang—6.5 metres

Distance ahead of king pin or point of attachment of tow bar to towing vehicle—3.0 metres

(SL5) Surf boats on trailers

Rear overhang—4.5 metres

(SL6) Yachts and pleasure boats on trailers and stanchions attached to the trailers

Width—2.9 metres

(SL7) Disabled regulation sized and overdimension vehicles that have been involved in a crash or suffered mechanical failure and are being towed by a breakdown recovery vehicle

Any of the dimension limits imposed by regulation 48B of the Traffic Regulations 1976 may be exceeded.

Second Schedule

Operating conditions

The special overdimension loads and vehicles described in this notice must be operated in compliance with the dimension limits and requirements set out in the corresponding documents SL1 to SL7 (inclusive) produced by the Land Transport Safety Authority.

Signed at Wellington this 19th day of August 1998.

W. R. PETTERSSON, Senior Engineer, Safer Roads.

gm6089

General Approval—Overdimension Agricultural Vehicles

Pursuant to regulation 49 of the Traffic Regulations 1976, and by way of a subdelegation from the Director of Land Transport Safety dated 18 December 1996, I, Wayne Robert Pettersson, Senior Engineer, hereby approve the operation of the vehicle types described in this notice contrary to the provisions of regulations 48B to 48D.

Vehicles of the types described in the First Schedule and which exceed the dimension limits described in the Second Schedule cannot operate unless a specific approval has been issued to that vehicle under regulation 49A.

This notice comes into effect on the 1st day of September 1998.

First Schedule

Types of Vehicles

Overdimension Agricultural Vehicles within the dimension limits described in the second schedule, including those not covered by the existing exemption in the Traffic Regulations 1976.

Definitions

In this schedule—

“Agricultural machine” means a motor vehicle (but does not include hedge trimmers, verge mowers and overwidth fertiliser spreaders) not being a trailer that has been designed exclusively for agricultural operations and is only used on a road when proceeding to or from a farm, or when being inspected, serviced or repaired.

“Agricultural operations” means operations concerned directly with the management of a farm.

“Agricultural trailer” means a trailer that has been designed exclusively for agricultural operations and is only used on the road when proceeding to or from a farm, or when being inspected, serviced or repaired.

“Agricultural vehicles” include agricultural trailers and agricultural machines.

“Auger” means a loading conveyor on a trailer used for agricultural purposes.

Second Schedule

Dimension limits

Overall width— 4.3 metres (see note below)

Overall length— 12.5 metres for an agricultural vehicle not towing a trailer

20.0 metres for an agricultural vehicle towing a trailer

25.0 metres for an agricultural vehicle towing an auger

Rear overhang— 6.0 metres for all vehicles except rear wheel steer harvesters which may exceed 6.0 metres

Front overhang (distance ahead of front of driver's seat)

5.0 metres (see note below)

Height—

4.25 metres

Note

The maximum permitted front overhang of 3.0 metres and/or width of 2.5 metres specified in the Traffic Regulations 1976 may only be exceeded if:

The driver has a virtually unobstructed 180 degree field of view when facing forward, or this view can be satisfactorily obtained by small head movements,

and

the implement is not a dangerous projection and is not readily detachable.

Projecting forks and exposed cutting surfaces are regarded as dangerous and must be removed and carried separately.

Implements attached by hydraulic linkages, or those fitted by mechanical means and able to be detached in less than 15 minutes, must be removed.

Permanently attached implements, which are an integral part of the machine, must not be dangerous fittings.

Third Schedule**Operating Conditions**

The agricultural vehicles described in this notice must be operated in compliance with the requirements set out in the document "Overdimension Agricultural Vehicles: A Guideline to Operating Requirements" dated August 1998 produced by the Land Transport Safety Authority.

Signed at Wellington this 19th day of August 1998.

W. R. PETTERSSON, Senior Engineer, Safer Roads.

gn6090

Index**B**

Bankruptcy Notices—

Notices: 2988, 2989, 2990.

Burial and Cremation Act—

Burial and Cremation Act (Operational Service) Notice 1998: 3033.

C

Charitable Trusts Act—

Approval of a scheme

New Zealand School of Dance: 3023.

Civil Aviation Act—

Airworthiness directives: 3038.

Exemption notices: 3038.

Companies Act—

Cessation of business in New Zealand:

Aroma Science Pty Ltd., 3018.

Prandf Pty Ltd., 3018.

Company removals list notices revoked:

Fuller Holdings Ltd., 3005.

Company removals list notices: 3005, 3006, 3012, 3014.

Removals notices:

Auto Infoline Ltd., 3018.

Balcairn Farm Ltd., 3017; Brendan McConnell Solicitors Nominee

Company Ltd., 3018; Bruce Penny Ltd., 3017.

Fluid Transport Services Ltd., 3018.

Gretener Farms Ltd., 3016.

Haitari Holdings Ltd., 3015.

Kered Ltd., 3016; Kowai Bush Enterprises Ltd., 3017.

Leafstock Ltd., 3017; Long Line Shoes NZ Ltd., 3015.

M P De Gouw Ltd., 3016.

River Valley Souvenirs Ltd., 3016.

Sancom Investments Ltd., 3015; South Pacific Cargo Ltd., 3015;

South Pacific Group Services Ltd., 3015.

Taihape Carriers Ltd., 3017; Tempo Services Ltd., 3018; The Baby

Boutique Ltd., 3015; The Caring Card Company (International)

Ltd., 3016.

W B Pehi Consultant Ltd., 3016.

Restoration to the Register of Companies revoked:

Medway River Vineyard Ltd., 3020.

Restoration to the Register of Companies:

A.C.Naidu Holdings Ltd., 3019; Amateur Game or Sport Promoter

Ltd., 3019; Assessment and Development Services Ltd., 3019.

B. Hosking Ltd., 3019; Baker Bros Service Stn Ltd., 3019; Bealey

Investments Ltd., 3019.

C.B.D. Apartments Ltd., 3019; Campbell Resources Ltd., 3019;

Community Security Ltd., 3019.

Debenture Securities Ltd., 3019.

Film Facilities Ltd., 3019; Future Build Ltd., 3019.

Geoffrey Dainty Ltd., 3019; Greymouth Pharmacy Ltd., 3019.

Hagley Developments Ltd., 3019; Hikoi Tours Ltd., 3019;

Homeseekers (NZ) Ltd., 3019.

Jorson Holdings Ltd., 3019.

Mold Technology Ltd., 3019.

Philip Peacocke Ltd., 3019.

Scandinavian Enterprises Ltd., 3019; Seaton Enterprises Ltd., 3019;

Shearton Developments Ltd., 3019; Straight Line

Communications Ltd., 3019; Swing Thru Canterbury Ltd., 3019.

Tuson Fishing Ltd., 3019.

Zarazel Trading Ltd., 3019.

Winding up/liquidation notices:

About Communication Ltd., 2999; Account Investment Ltd., 2999;

Aeroport New Zealand Shuttle Express and Tours Ltd., 3001; AJ

& NU Dobbyn Ltd., 3004; Alwest Aluminium Ltd., 2992;

Auckland Building Services Ltd., 3002; Azalea Investments Ltd.,

2999.

Bangkok Kitchen and Bar Ltd., 2993; BGL International Ltd., 2999;

Bogarts Pizza Ltd., 2996; Briteway Industries (Auckland) Ltd.,

3001; Burslem Group Ltd., 2999.

Camatos Holdings Ltd., 2998; Chelsea First National Ltd., 3002;

Classic Bathrooms Ltd., 2999; Cosfort Holdings Ltd., 2992;

Cutter Douglas Architects Ltd., 2995.

Deco Bay Ltd., 2997; Delos Enterprises Ltd., 3000, 3004; Dress

For Less Ltd., 3002.

Eastern Haulage Ltd., 2997; Evans Pneumatics Ltd., 2999.

French (Asia Pacific) Ltd., 3001; Friends Restaraunt Ltd., 2995;

Future Card Management Ltd., 2996.

G.S. Lintott & Company Ltd., 2998; G.W. Rennwandt Ltd., 2993;

Ganley Refrigeration Services Ltd., 2999; General Capital and

Commerce Ltd., 2997; Gilando Enterprises Ltd., 2999; Global

Construction Ltd., 2999; Global Mortgage Securities Ltd., 2995.

Halford Refrigeration Ltd., 3002; Hallam Engineering Ltd., 2992;

Hillcrest Construction Ltd., 3001.

Independent Taverns Ltd., 3000, 3004; Instore Interiors Ltd., 2999.

K B J Devlin Ltd., 3001; Kahury Holdings Ltd., 3003; Kite Moana

Oysters Ltd., 2999; Kiwi North Nine Ltd., 2999; KT Footwear

Ltd., 2995; Kusan Corporation Ltd., 2999.

Magneto Properties Ltd., 2992; Maritime Duty Free Sales Ltd.,

3000; Meichtry Investments Ltd., 2993; Metro Consulting Ltd.,

2993; Mobile Marine Ltd., 2999; Mobile Sawmillers Ltd., 2999;

Moonshine Enterprises Ltd., 3000, 3004.

- N.E.U. New Zealand Europe Group Ltd., 2998; Nakano Construction (NZ) Ltd., 3000, 3003, 3004; Nelson Battery Services Ltd., 3002; New Zealand Dairy System Ltd., 2994; Nordica Investments Ltd., 3000, 3004.
- OC & RS Williams Ltd., 2991; Omega Chi Holdings Ltd., 2999.
- Pene Brothers Ltd., 2998; Plumley Holdings Ltd., 2992.
- Rathgar Enterprises Ltd., 2998; Rix New Zealand Ltd., 2997; Royal Jelly New Zealand Ltd., 2997; Ruapehu Directional Drilling Ltd., 2991; Rushden Properties Ltd., 2994.
- Sash Painting Services Ltd., 2993; Saxony System Ltd., 2994; Seven Traders Ltd., 3001; Sheehans Wines & Spirits Ltd., 3000, 3004; Summersun Nurseries Ltd., 3003.
- Te Aupouri Ngatikahu Te Rarawa Trust, 2994; Te Puke Memorial Aquatic Centre Trust Board Incorporated, 2999; Top Notch Plasterers Ltd., 2994; Trailer Sign Rentals Ltd., 2996; Trans Capital (Euro) Ltd., 3003; Trans Capital Ltd., 3003; Turbo Designer Menswear Ltd., 2995.
- Waipuna International Ltd., 2996; Wakatipu Club Incorporated, 2996; Wellington Concrete Products Ltd., 2993; West Penn Holdings Ltd., 2995; Wine Castle Ltd., 3002.
- Xedos Distribution Ltd., 2999.
- Conservation Act—
 Appointments: 3024.
 Establishment of conservation boards: 3024.
 Land notices:
 Far North: 3040.
 Horowhenua: 3041.
 Hurunui: 3040.
 Waimakariri: 3040.
 Waitaki: 3040.
- Criminal Justice Act—
 Confiscation of motor vehicles: 3029, 3030.

D

- Domestic Violence (Programmes) Regulations—
 Appointments: 3030.

E

- Education Act—
 Boards of trustees election notices
 St Brendan's School: 3031.
 The Correspondence School: 3031.
 Establishment of a primary school
 Doncaster Drive Primary School: 3031.

F

- Fire Service Act—
 Fire district notices
 Dunedin: 3040.
- Fisheries Act—
 Fisheries notices
 Quota aggregation limit exemption: 3031.
- Fisheries (South Island Customary Fishing) Regulations—
 Fisheries (South Island Customary Fishing) Notice 1998: 3032.
- Friendly Societies and Credit Unions Act—
 Registration of instrument of dissolution
 Totara Lodge: 3023.

G

- Gaming and Lotteries Act—
 Permission to conduct a lottery: 3034.

H

- Harbour Boards Dry Land Endowment Revesting Act—
 Land declared to be a reserve
 Tauranga: 3041.

J

- Judicature Act—
 Appointments: 3030.
 Winding up / liquidation notices:
 Wakatipu Club Incorporated, 2996
- Justices of the Peace Act—
 Appointments of Justices of the Peace: 3036.

L

- Land notices—
 Other Cities
 Waitakere: 3042.
- Other Districts
 Papakura: 3051.
 Waikato: 3050, 3051.
 Whakatane: 3048, 3049.
 Whangarei: 3042, 3043, 3044, 3051.
- Roading Cities
 Auckland: 3050.
 Christchurch: 3048.
 Napier: 3042.
 Nelson: 3047, 3048.
 Upper Hutt: 3049.
 Waitakere: 3042.
- Roading Districts
 Central Otago: 3047.
 Franklin: 3044.
 Hastings: 3042.
 Kaiwaka: 3047.
 Mackenzie: 3047.
 Tasman: 3048.
 Waipa: 3046, 3049.
- Land Transfer Act—
 Land Registrar notices—
 Auckland: 3022.
 Blenheim: 3020.
 Christchurch: 3020.
 Dunedin: 3021.
 Gisborne: 3023.
 Hamilton: 3021.
 Napier: 3021.
 Nelson: 3021.
 New Plymouth: 3022.
 Wellington: 3022.

M

- Marriage Act—
 Approval of organisations: 3034.
 Lists of marriage celebrants: 3034, 3035.
 Marriage celebrants removed from lists: 3035.
- Medicines Act—
 Classification of medicines: 3033.
 Renewal of provisional consent to the distribution of new medicines:
 3032.

O

- Oaths and Declarations Act—
 Officers authorised to take statutory declarations: 3037.

P

- Patriotic and Canteen Funds Act—
 Appointments to the New Zealand Patriotic and Canteen Funds Boards:
 3035.
- Privacy Act—
 Code of practice notices: 3037.
- Private Schools Conditional Integration Act—
 Supplementary integration agreement notices: 3031.

R

- Receiverships Act—
 Appointment and release of receivers and managers
 Coastal Aluminium (1996) Ltd., 2991.
 Fast Forward Blowmoulding Ltd., 2991; Fast Forward Moulding
 Ltd., 2991.
 Waihemo Timber Company (1997) Ltd., 2991.
- Regulations (Acts and Regulations Publication Act)—
 Extradition (Hong Kong Special Administrative Region of the People's
 Republic of China) Order 1998 (S.R. 1998/243): 3051.
- Fisheries (South Tasman Rise Orange Roughy Fishery) Regulations
 1998 (S.R. 1998/240): 3051.
- Health and Disability Services Amendment Act 1998 Commencement
 Order 1998 (S.R. 1998/239): 3051.
- Income Tax (Fringe Benefit Tax, Interest on Loans) Amendment
 Regulations (No. 3) 1998 (S.R. 1998/245): 3051.

Residential Tenancies (Fees) Regulations 1998 (S.R. 1998/244): 3051.
 Securities Act (Govett Oriental Investment Trust PLC) Exemption Notice 1998 (S.R. 1998/238): 3051.
 Securities Act (Industry Retirement & Insurance Services Limited) Exemption Notice 1998 (S.R. 1998/246): 3051.
 Social Security (Invalid's Benefit) Regulations 1998 (S.R. 1998/241): 3051.
 Social Welfare (Reciprocity with Australia) Amendment Order 1998 (S.R. 1998/242): 3051.

Reserves Act—
 Reserves Cities
 Napier: 3041.
 Reserves Districts
 Hastings: 3041.

S

Sale of Liquor Act—
 General election of members
 Ashburton Licensing Trust: 3037.
 Oamaru Licensing Trust: 3037.

Securities Amendment Act—
 Designations under section 6 (1) (a): 3040.

T

Traffic Regulations—
 Exemption notices: 3038, 3039.
 General approval notices
 Overdimension agricultural vehicles: 3058.
 Overdimension mobile cranes: 3054.
 Overdimension vehicles and loads: 3052.
 Special overdimension loads: 3057.
 Special overdimension vehicles: 3056.
 Transport (Vehicle Standards) Regulations—
 Exemption notices: 3038, 3039.

V

Veterinarians Act—
 Appointments: 3023.



